



LUTUM Roof Tiles Technical Information Guide

August 2022

LUTUM
AUSTRALIAN ROOFING & MASONRY

Contents

Introduction

Foreword	5
Important	5
Quality Control	5
Specifications	5
Local Authorities	5
Performance	5
Safety	5
Designer Ceramic + Terracotta	6
Concrete	6
Roofing Terminology	7

Design Considerations

Code Considerations	13
Standards	13
Bushfire Attack Levels (BAL)	13
Wind Forces	13
Terrain Categories	14
Basic Wind Regions	15
Fixing Tile Roofs in Cyclonic Regions	16
Minimum Roof Pitch	16
Maximum Rafter Lengths	16
Maximum Rafter Lengths - No Sarking	16
Sarking	17
Insulation	17
Ventilation	17

Performance Characteristics

Thermal Performance	19
Acoustic Performance	19
Water Collection	19
Testing: AS 2049 - Roof Tiles	21
Testing: AS 2050 - Installation of Roof Tiles	21
Fire Resistance	22

Terracotta Roof Tiles

French™	24
Swiss™	25

Designer Ceramic Roof Tiles

Artline®	27
Shingle™	28
Wave™	29

Concrete Roof Tiles

Capri™ SA	31
Contour™ NSW, ACT & VIC	32
Linea™ NSW, ACT & QLD	33
Linea™ SA	34
Linea™ VIC	35
Macquarie™ NSW, ACT, QLD & VIC	36
Slimline™ NSW, ACT, QLD & VIC	37
Striata™ SA	38
Striata™ VIC	39
Vogue™ NSW, ACT & QLD	40
Vogue™ SA	41
Vogue™ VIC	42

Accessories

Terracotta Accessories	44
Designer Ceramic Accessories	46
Concrete Accessories	47
General Accessories	48

Installation Details

Preparation for Installation	50
Tile Set Out	50
Counter Battens	53
Valleys	54
Fascia Height	54
Barge Height	55
Anti-Ponding Boards	55
Laying the Roof	55
Roof Tile Fixing Systems	56
Sarking	57
Ridge Systems	58
Ridge Installation	58
Hip Details	61
Valley Boards	61
Sarking at Valleys	61
Valley General	62
Barge/Gable Systems	62
Roof and Flashings Details	64
Bedding and Pointing	66
Roof Completion	88

Architectural Details

68

Frequently Asked Questions

84

A QUALITY FINISH, WITH A QUALITY LOOK TO YOUR JOB

When you choose LUTUM roof tiles you know you are getting a quality product. A quality product that will last. A quality product that will look great not only on handover, but for many years to come.

Whether you are building a new home or renovating an existing pitched roof, LUTUM's range of unique designs and colour profiles gives choice to individualise and complement the entire home.

Choose from LUTUM's attractive Concrete or exceptional and long-lasting Terracotta and Designer Ceramic tiles. LUTUM Concrete tiles are made from sand and cement that gets stronger with age. LUTUM Terracotta and Designer Ceramic tiles are made from natural Australian clay resulting in a strong, yet lightweight roofing material, of exceptional quality and colour that never fades.

LUTUM roof tiles have been manufactured to the highest Australian standards for over 50 years, which is why we confidently provide a customer guarantee of 20 years on all LUTUM Concrete tiles, 50 years on LUTUM Terracotta tiles and 60 years on LUTUM Designer Ceramic tiles.

To ensure quality standards, LUTUM maintains a fully-staffed Quality Control Laboratory where LUTUM tiles are constantly tested for weight and dimensional stability, transverse strength, water absorption, permeability and colour consistency in compliance with Australian Standard AS2049 for Roofing.

LUTUM roof tiles provide a great investment for your clients that will add pride and value to their home for its entire life.

SERVICE AND SUPPORT YOU CAN DEPEND ON

At LUTUM we pride ourselves on our roofing expertise to help you complete your job on-time and to your client's total satisfaction.

Our LUTUM supply service is here to help you with all your needs. We will work with you to help plan your job. From helping you with technical expertise, to estimating the exact numbers of tiles, ridges, apexes and valleys to having all the accessories including sarking and battens that you will need to complete your job.

LUTUM will also deliver direct to your job-site or if you prefer, you can pick up directly from one of our 5 Australian locations. Our team is also on-hand to support you with any queries you may have, at any time before, during or after completion of your job.

You can trust LUTUM's technical know-how to work out all your tiling needs so all you have to do is supply and install your LUTUM roof tiles.

50 YEARS AS PROACTIVE AND ACCOUNTABLE PARTNERS

LUTUM (formerly Boral Roofing and Masonry) has been manufacturing, supplying and installing roof tiles and masonry products to the Australian building industry for more than 50 years.

Over this time, we have demonstrated a strong commitment to building enduring partnerships with builders and distributors through a mix of proactive determination and accountability.

We listen and we respond proactively and will always be accountable for our service and our product quality. All LUTUM staff have the freedom to pursue customer-focussed ideas and initiatives while being held accountable to what they promise. This ensures we are always looking for ways to help your business succeed while at the same time being fully responsible for our actions as a trusted supplier of quality products.

What this ultimately means is that we always strive to be trusted and easy to do business with.



LUTUM Roof Tiles Technical Information Guide

Introduction

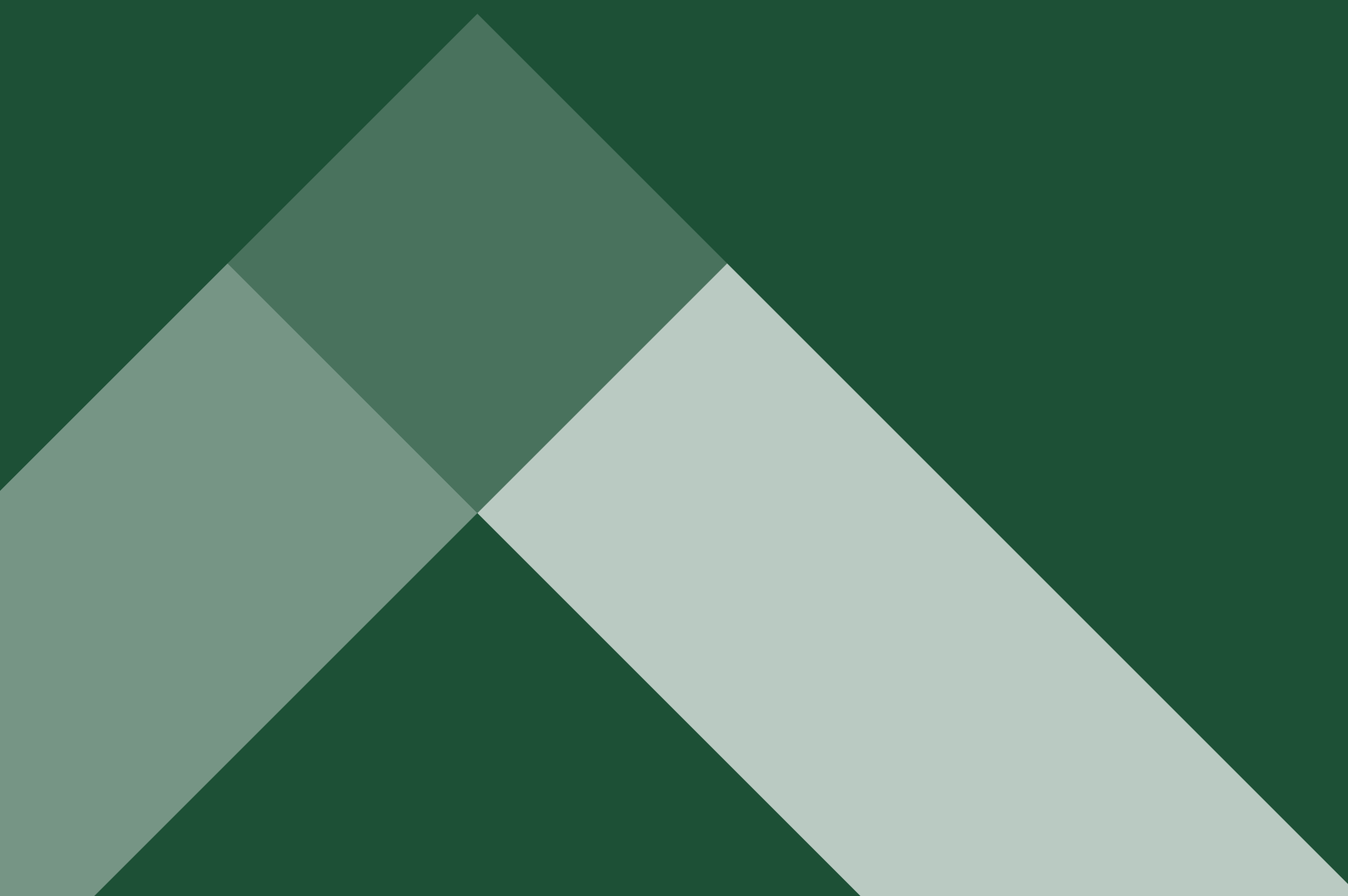

Introduction

Foreword

This manual has been prepared to assist the builder, architect and installer, to specify, detail, prepare and install LUTUM roof tiles. While it is not possible to list and detail every condition that may be encountered, LUTUM will assist and advise on any special situations that may occur.

It should be noted that the manual has been written as a working guide for industry, however it is not intended to replace good trade practice and the long trade experience essential to obtain a quality roof installation. LUTUM recommends that installation is carried out by a professional roof tiler.

Important

All care has been taken in the compilation of this manual, however LUTUM accepts no responsibility nor liability for the contents of the manual (including any printing or typographical errors) and recommends that all standards, specifications and recommendations be independently checked.

These roof tile fixing specifications should be applied in the following context - in conjunction with, but subordinate to, the Building Code of Australia, Australian Standards, State codes and regulations.

Architects and specifiers should not only ensure that the details provided in this manual are followed, but should determine to their own satisfaction that the job is completed to an acceptable standard of trade practice.

Note:

The instructions and details in this manual refer to both concrete and terracotta tiles (except where specifically noted).

Quality Control

LUTUM maintains a fully staffed Quality Control Laboratory. The product is tested for weight and dimensional stability, transverse strength, water absorption, permeability and colour consistency.

Specifications

Production information contained in this leaflet is correct at the time of printing, however specifications are subject to change without notice.

LUTUM liability is limited to the replacement of product should it fail to perform as specified in literature current at the date of manufacture.

Local Authorities

Fixing standards and product specifications contained in this leaflet are minimum recommendations based on Australian Standards and good industry practice. It is however recommended that local authorities are consulted as they may require different standards to be met.

Performance

LUTUM roof tiles should perform as specified if fixed in accordance with good trade practice and recommendations set down in this and other relevant literature.

The objective of these specifications is to provide up-to-date information for architects, building contractors and all persons responsible for purchasing and installing roof tiles. The material covers the range of LUTUM roof tiles and accessories available in Australia, and the preferred methods and standards for fixing tiles, including special treatments.

The following points should be noted:

- The need to encourage the highest standards of trade practice to ensure long lasting and attractive roof finishes.
- The need to encourage compatibility between overlapping trades on building sites.
- The full range of products may not be available or applicable to all states at this time.
- Uniform fixing methods are given but there are some variations in procedure from state to state. Advice should be obtained locally.

Special fixing standards apply to designated high wind areas.

Safety

Federal, State and Territory WHS Acts and Regulations and Codes of Practice set out specific safety requirements and arrangements for working at heights that every workplace shall enforce in order to meet their legal responsibility of providing a safe working environment.

The following minimum mandatory requirements shall be implemented to ensure LUTUM workplace compliance in relation to working at heights:

- Undertake a risk assessment before starting any work.
- The site/operations manager or their delegate shall identify tasks and locations that are likely to require working at heights and record tasks.
- A Safe Work Method Statement (SWMS) shall be completed and approved by a competent Supervisor before any work

» Introduction

occurs and whether the scope of work changes or the risk of a fall increases.

- The site/operations manager or their delegate shall design and implement safe access systems, where required.
- Controls shall be implemented to reduce risks to as low as reasonably practicable when working at heights is required.
- Forklift work platforms are not permitted to be used.
- Personal fall-arrest equipment should only be used when all other control measures have been explored and deemed to be not reasonably practicable.
- Where electrical power lines are in the working at heights area, electricity network supplier shall be contacted to determine clearances.
- All equipment shall be fit for its intended purpose and pre-start checks shall be undertaken before use.

Working on Roofs

- All work on roofs shall be conducted in accordance with regulated Australian Standards and relevant Codes of Practice.
- Where personnel are required to work within two metres of a roof edge, or on brittle or fragile material, fall-prevention measures shall be utilised unless otherwise qualified in relevant Codes of Practice.
- Permanent or temporary guard rails and walkways are preferred; however, if these are not practicable, alternative control measures shall be used (eg static line systems or scaffolds).
- Brittle or fragile roofing materials shall be protected with appropriately secured wire to protect inadvertent falls through the material.

Other Safety Considerations

- Take care when moving or unpacking. Personal protection equipment, including eye protection, should be worn at all times when handling roof tile packs and cutting straps. Straps are under tension and may snap and/or recoil. Additionally, roof tiles may collapse when unwrapped.
- Avoid inhalation of dust when cutting roof tiles as it may contain traces of crystalline silica. Take care by wearing appropriate PPE such as eye protection and a Class P1 (particulate) dust mask.
- Please refer to SDS for specific safety information, available at www.lutum.com.au

Designer Ceramic & Terracotta

Meaning ‘baked earth’ in Italian, terracotta, as the name suggests is a natural clay product that has been used throughout the ages for protection against the elements.

LUTUM terracotta tiles and the Designer Ceramic range are manufactured using prepared clays that are kiln-fired to temperatures of 1100°C, resulting in a strong yet lightweight roofing material of exceptional quality.

Natural Beauty of Designer Ceramic & Terracotta

High Quality Premium finish

Made from natural clay, the tiles exude character and quality that cannot be replicated. Various finishes are available with a choice of full glazed, semi-glazed, matt glazed or un-glazed tiles.

Superior Colour-fast properties

The outstanding colour performance of glazed, semi-glazed, matt glazed and un-glazed tiles is achieved during the firing process at temperatures of 1100°C. The process known as vitrification provides a finished tile resistant to harsh UV exposure. The colour is “locked in” and will remain vibrant for years to come.

Design Flexibility

Designer Ceramic comes in three profiles; Wave™, Artline® and Shingle™. While Terracotta roof tiles offer two distinct profiles; French™ and Swiss™. These combine to provide great design flexibility to achieve a wide range of house designs.

Concrete

Modern Concrete tiles, made from cement, graded sands and pigments, can replicate the appearance of a broad array of distinctive tile designs. As such they offer the widest selection of profiles and colours, while remaining relatively cost-effective.

LUTUM Concrete tiles are manufactured using an extrusion process resulting in the utmost strength and density. Following moulding and colouring we apply a sealant finish that protects against efflorescence, a salty white deposit that can form on masonry and concrete products.

Numerous accessories are available to enhance the overall appearance of a concrete tiled roof.

» Introduction

Enhanced Versatility of Concrete

Outstanding value

With proven performance and an attractive appearance, concrete tiles are one of Australia's most popular choices for value for money.

Enduring Strength

Our Concrete tiles are manufactured from durable concrete made to strict strength specifications, with strength improving with age.

Extensive Colour Range

Whether it's the vibrancy of our colour-on surface finishes or the longevity of colour through options, there is a concrete tile to complement any colour scheme.

Water Absorption

Extruded Concrete tiles are made from cement and graded sands to ensure the body of the tile conforms to the requirements of the Australian Standard for water absorption of less than 10%.

Roofing Terminology

Abutment

Where the roof tiles meet a brick or timber structure rising above the roof.

Accessory

A concrete or terracotta product used to finish the roof; includes apex, ridge and barge tiles.

"A" Frame Roof

A steep pitched gable roof, each slope extending from close to the ground line to meet at the top ridge.

Apex

The intersection of all ascending hips where they meet either a ridge or another ascending hip (also the name of a three-or-four-way fitting used to cover this point).

Apron Flashing

A one piece flashing, such as used at the lower end of a valley, spilling onto a lower roof.

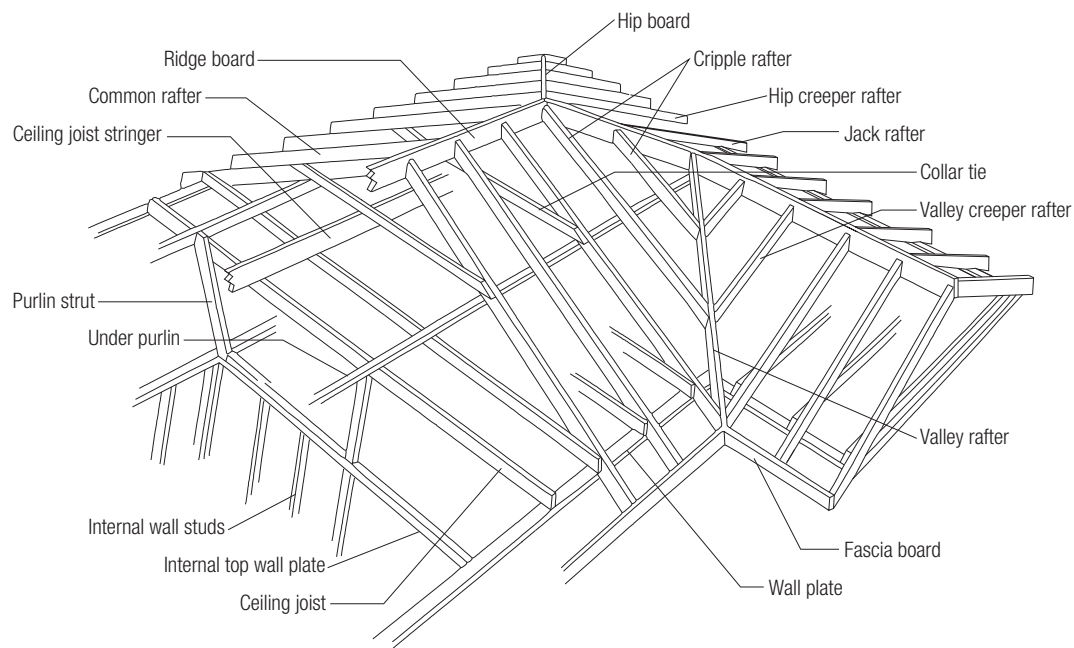

Figure 1: **Roof Structural Members**

» Introduction

Anti-Ponding Board

A lining of various materials (galvanised iron, fibrous cement etc) fixed along the eaves lines from the top of the fascia, back to the rafter with a clearance of 10mm below the first batten.

Barge Board/Verge Board

A sloping board parallel with the pitch of the roof along a gable, covering the Gable Board: ends of roof timbers.

Barge Course/Verge Course

The tiles next to the gable, which overhang it slightly.

Bastard Valley or Hip

A valley or hip formed in an abnormal or non-parallel line on which tiles are fixed.

Battens

Selected sized timber fixed parallel to the eave line on which tiles are fixed.

Bedding

Composition of sand and cement for fixing ridge capping on hips and ridges.

Bellcast Batten: (Tilting batten)

A batten fixed on the toe of the rafters in a vertical line with the plum cut, to keep the eaves course of tiles on the same rake as the other courses (the fascia board generally serves this purpose).

Bond

The system of aligning tiles on the roof in relationship to each other. With straight bond, the sides of tiles form straight lines from bottom to top course. With staggered, broken or cross bond, tiles in each alternate course overlap, by half, the tiles above and below them. For installation as a quarter bond (Linea) tiles, in each alternate course overlap by a quarter of the tile width.

Box Gutter

An internal roof gutter between the slopes of a roof or a roof and a wall that discharges water internally through a sump.

Capillary Break

A groove or space left between two surfaces, large enough to prevent capillary movement of water into a building.

Ceiling Joist

The joists that carry the ceiling and also form a tie between the feet of the common rafters.

Cleat

A small piece of wood reinforcing another or used to locate positively another timber.

Collar Tie

The timber used to connect two rafters near their approximate centres.

Concealed Gable Flashing

Normally a galvanised strip with an internal lip fixed under the fibre cement verge strip and running to the gutter line.

Counter Battens

A batten normally fixed on top and parallel to the rafters over the ceiling lining where the ceiling lining is fixed on top of the rafters (exposed beams). Tiling battens are then fixed to the counter battens, creating an air space, allowing sarking to dish between the rafters.

Creeper Rafters

Short rafters spanning between ridge and valley, reducing in length at the end, which joins the valley rafter.

Cripple Creepers

Joins the valley rafter to the hip rafter.

Dormer or Dormer Window

A vertical window or opening, coming through a sloping roof and usually provided with its own pitched roof.

Dormer Cheek

The upright side to a dormer.

Dutch Gable

A roof having a gable near the ridge and the lower part hipped.

Eave or Eaves

The lowest overhanging part of a sloping roof, which projects beyond the external wall.

Eaves Fascia

A board on edge fixed along the feet of the rafters. It often carries the eaves gutter along the eaves.

Facade

The face or front of a building normally of steep elevation.

Fascia Board

A wide board set vertically on edge, fixed to the rafter ends or wall plate or wall. It carries the gutter.

» Introduction

Fall

The slope or pitch of a roof or gutter.

Finial

Usually a pointed ornament at the top of a gable, hip junctions and dutch gables.

Fire Wall

A wall that divides a building to resist the spread of fire. Gaps between the top of the fire wall and the underside of the roofing material are to be filled with a fire resistant material.

Flapping

A noise caused by wind passing over a tile roof making sarking flap against the underside of the batten and tile. Anti-flap pads can be used to overcome this problem.

Flashing

A strip of impervious flexible metal, which excludes water from the junction between a roof covering and another surface usually vertical.

Gable or Gable End

The triangular part of the end wall of a building with a sloping roof.

Gable Roof

A roof where two sloping planes join creating a gable end at one or both ends.

Gable Splayed

The gable that does not run parallel with the roof slope and runs at an angle from an extended ridge.

Gauge

The distance between the roof tile battens.

Gauge Stick

A stick made from straight battens approximately 1800mm long, marked by saw cuts at the correct gauge or set out for the tiles being used.

Glaze

A "frit" (glaze) fired onto the surface of terracotta roof tiles to provide various colours.

Gutter

Any form of roof water channel, viz:

- Back Gutter – a gutter at the back of a chimney or other penetration in a pitched roof.
- Box Gutter – a gutter with parallel sides, usually between two opposing roof slopes.
- Concealed Gutter (Secret Gutter) – a gutter formed at a valley or against an abutment and concealed by the tiles and flashing.
- Eaves Gutter – a gutter fixed at the eaves.
- Valley Gutter – a gutter at the internal junction of two roof slopes

High-Wind Area

Areas in which the basic design and wind velocity, modified for terrain and height in accordance with AS 1170.2, has a wind classification N3/C1 or greater.

Hip

The edge formed by the meeting of two pitched roof surfaces.

Hip Board

The board, set on edge, at which the hip rafters meet.

Hip Capping (Ridging)

A shaped capping on hips to prevent water penetration.

Hip End

The sloping triangular end of a hipped roof.

Hipped Roof

A roof, which has four slopes instead of the two slopes of the ordinary gabled roof. The shorter sides are roofed with small sloping triangles, called the hipped (hip) ends, which are bounded by two hips above (meeting at the ridge) and eave below. Normally the eaves area at the same level all round.

Jack Rafter

The rafters are shorter than the common rafters and cut against the hip or valley rafters.

Lap

The distance by which one course of tiles overlaps the course below.

Lifts

Roofing trade term for stacks of tiles around the roofs.

» Introduction

Loading

The fixing, as specified by the tiling manufacturer, of sarking, battens, tiles and accessories shall be sufficient for the completed roof to withstand the loading requirements of AS 1170.1, AS 1170.2 and AS 4055.

Mansard Roof

A roof structure with two pitches, one a steep pitch and one a low pitch on each side of the ridge line. The steep pitch commences at the eaves, and intersects with the lower pitch, which finishes at the ridge. Tiles on the lower pitch overhang the steeper pitch by a slight margin.

Mitred Hips/Valleys

Cut tiles on hips or valleys forming a true and straight line where the cut tiles join on each slope.

Mortar

See "Bedding".

Mottle

The phrase used to lay various coloured tiles at a consistent percentage throughout the roof.

Nogging

Short pieces of timber nailed between studs in a wall to stiffen the structure.

Parapet Wall

Usually a brick or timber structure rising above the roof line.

Picking Up

The term used when the tiler is trowelling off any excess mortar that may overhang the ridge capping after bedding.

Pitch

The ratio of the height to the span of a roof, or its angle of inclination to the horizontal.

Pointing

A mixture of clean sand, cement and oxide colouring or a pre-mixed flexible material used for the completion of joints between ridge or hips and with roof tiles or tiles at gable ends.

Profile

The end elevation or cross section of the tile to indicate shape and design of the tile.

Purlin

A horizontal beam in a roof, at right angles to the principal rafters or trusses. It carries the common rafters if there are any.

Rafter

A sloping timber extending from the eave to the ridge of a roof.

Rake

The roof's angle of inclination from the horizontal.

Ridge

The apex of a roof, usually a horizontal line.

Ridge Board

The horizontal board set on edge, at which the rafters meet.

Ridge Capping

A covering over a ridge line either "V" shaped or arched (rounded). This is generally a specifically made tile used for both the ridge and hips of a roof.

Roof

A covering to protect a building from the elements.

Roof Tile

A concrete or terracotta product used to form the field of the roof.

Sarking

Reflective foil fixed under the tile battens and conforming to AS/NZS 4200-1-2.

Saw Tooth

The roof structure, which is vertical on one side with a slope from the ridge line on the other.

Secret Gutter

A gutter usually fixed against a wall adjoining the roof slopes, concealed by the roof covering and vertical wall flashing, then spilling into an eaves gutter.

Scribe Board

A type of barge board shaped to the same profile formed by the under surface of roof tiles, overhanging a gable end. The tiles, which overhang are pointed up on the interlocking joints.

Skillion

Term for low pitched roof continuing from the main slope or running off a wall.

» Introduction

Skylight

A glazed window or translucent roof section fitted parallel to the roof slope to admit light.

Sheathing

A close boarding or other material, nailed to the framework of wall or roof. Sometimes referred to as sheeting.

Soaker

A concealed flashing under tiles, slates etc, or mitred hips and parapet walls, shaped and fixed to discharge water on the tile or slate of the course below.

Soffit

The lining fixed under the eaves between the fascia board and external wall.

Soffit Bearer

Timbers used to support the soffit.

Spouting

See 'Gutter'.

Staggered Bond

The method of laying tiles whereby the vertical joint of every tiles is laid to overlap with a half bond of the tiles in the course below.

Starter/Shell End

The first hip cap at the lowest point of the hip line.

Straight Bond

Where tiles are not staggered, but are laid directly on top of the tile in the course below, so the vertical joints form one straight line up the slope of the roof.

Steel Battens

Steel battens shall be designed in accordance with AS 1538. They shall be manufactured of galvanised steel, of at least commercial grade, with a corrosion-resistant coating of a minimum of 300g/m of zinc.

Stud

A vertical wall support.

Top Plate

The horizontal timber above a wall on which the truss or rafter sits.

Tilting Batten

Serves the same purpose as bellcast batten.

Tile Clip

Specially formed metal fastening used to secure tiles to supporting members.

Truss Roofs

A self supporting structural timber frame work of triangular shaped members. Usually prefabricated and delivered to job site. This type of construction is commonly used in all types of roofs.

Upright Work

Tiling carried out on a roof pitched close to vertical, normally on a facade front, or a mansard roof.

Valley

The intersection between two sloping surfaces of a roof, towards which water flows, the opposite of a hip.

Valley Iron/Tray

A "V" shaped sheet lipped on each outside edge and formed to fit into the angle of the valley structure.

Valley Batten

A tiling batten fixed parallel to each side of the valley board. It must be fixed on all valleys when the roof is sarked.

Vent

Any pipe or tube protruding through the roof covering, normally circular in shape.

Verge

The edge of a sloping roof, which overhangs a gable.

Weephole

A small hole inserted in the ridge bedding and pointing mortar at the water channel of the tile for draining purposes.

Z Flashing

Normally a galvanised strip with an internal lip fixed under the fibre cement verge strip and run into the gutter line.

LUTUM Roof Tiles Technical Information Guide

Design Considerations

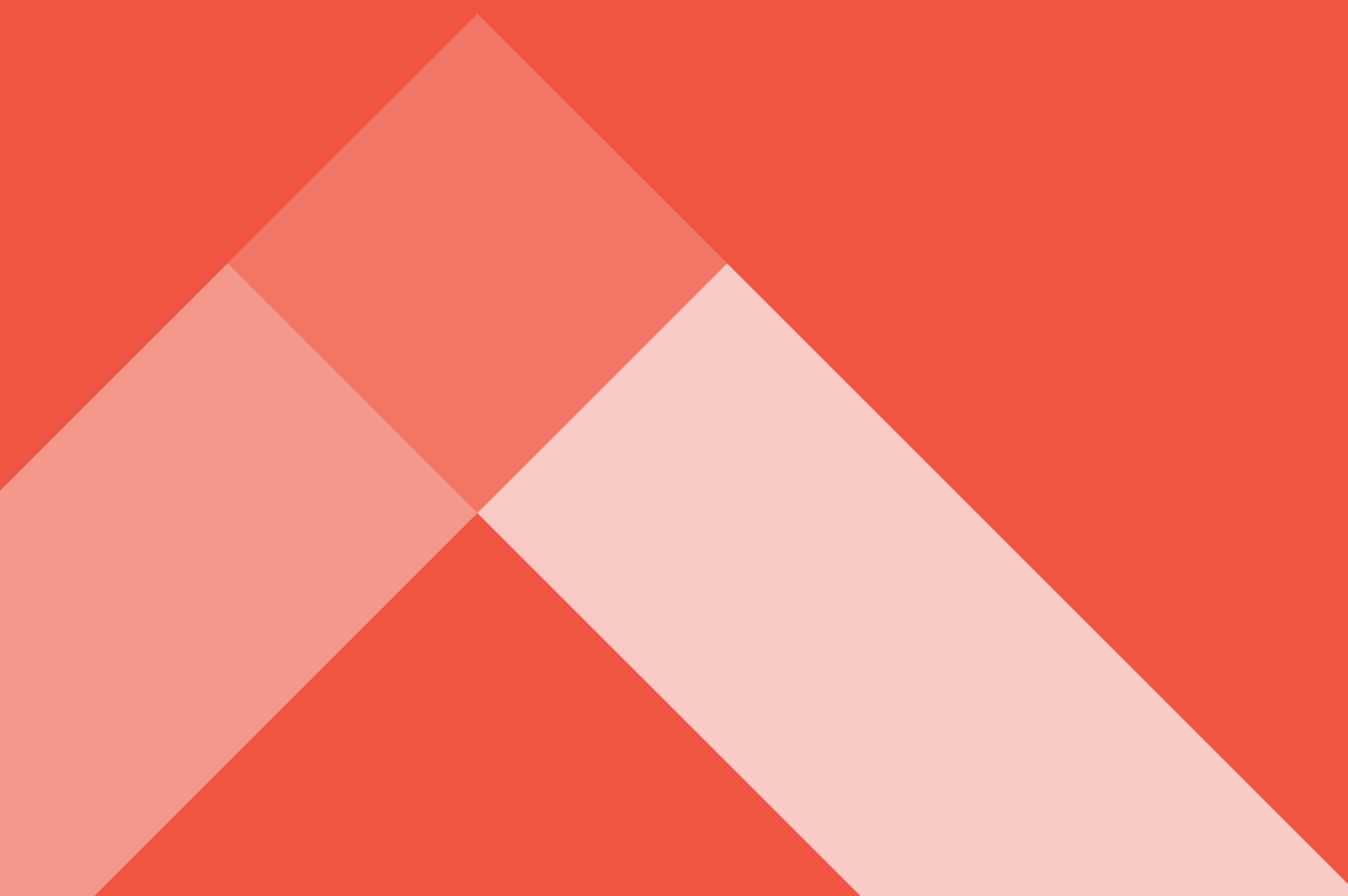

Design Considerations

Code Considerations

The design of a roof requires the consideration of many building codes and standards.

The following sections and tables summarise the major design requirements applicable to roof tiles. These requirements are by no means exclusive, as there may be any number of local regulative requirements of covenants. Specifiers are advised to ensure they have fully determined the local requirements.

Standards

The following Australian Standards apply:

- The Building Code of Australia Volume 2, Class 1 and 10 Buildings
- AS 2049 (Roof Tiles)
- AS 2050 (Installation of Roof Tiles)
- AS 4200.2 (Pliable Building Membranes and Underlays Part 2, Installation Requirements)
- AS 1170.2 (Wind Loads)
- AS 4055 (Wind Loads for Domestic Housing)
- AS 3959 (Construction of Building in Bushfire-Prone Areas)
- LUTUM Tiling Standards Guide.

Bushfire Attack Levels (BAL)

BAL-LOW

Normal fixing requirements for nominated wind classification.

BAL-12.5

Normal fixing requirements for wind classification N1 and N2, plus an approved sarking* and anti-ponding boards.

BAL-19

Normal fixing requirements for wind classification N3, plus an approved sarking* and anti-ponding boards.

BAL-29

Normal fixing requirements for wind classification N4, plus an approved sarking* and anti-ponding boards.

BAL-40

Normal fixing requirements for wind classification N4 and C2/C3, plus an approved sarking* and anti-ponding boards.

Note:

- *Extreme winds can be generated during bushfires. Fixing requirements should be increased as a precaution against the higher winds.*
- *LUTUM recommends the fixing requirements nominated in BAL-12.5 through to BAL-40 to allow for the greater winds expected.*
- *LUTUM recommends the installation of anti-ponding boards in all instances where sarking is used to satisfy BAL requirements.*

* Approved sarking shall be rated Low having a flammability index less than 5. Sarking to be located directly below the roof tile batten; cover the entire roof area including the top ridge; and be installed so that there are no gaps, which would allow entry of embers where the sarking meets fascias, valleys and the like.

BAL-FZ

Buildings in the Fire Zone require specialised materials and installation. Contact LUTUM for further information.

Wind Forces

Wind forces must be considered when designing or specifying roof structures and roofing materials. The forces involved may take the form of positive or negative pressure (suction).

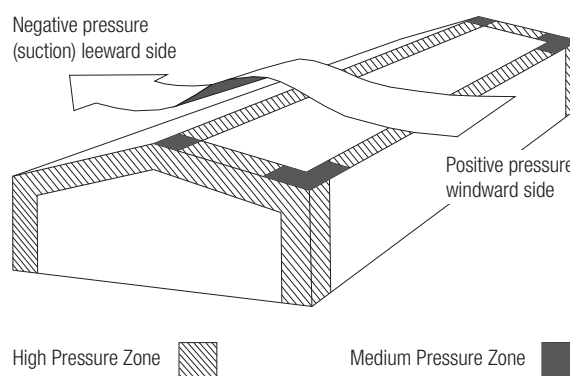

Figure 2: Wind Forces on Roofs

The magnitude of these forces are affected by regional wind velocities, exposure and building configuration.

The methods for determining these are set out in:

- AS 1170.2 (Wind Loads)
- AS 4055 (Wind Loads for Domestic Housing).

» Design Considerations

Terrain Categories

The effect of local buildings, hills and vegetation is taken into account by the code as local structures and terrain features will dissipate the force of the wind.

The four defined terrain categories are assessed by the direction and speed the wind flows towards a structure. Those quoted are in accordance with AS 1170.2.

Terrain Category 1, $Z^{\circ} = 0.002\text{m}$

Exposed open terrain with few or no obstructions, in which the average height of objects surrounding the structure is less than 1.5 metres. This category includes water surfaces (open sea coast and lakes), flat and treeless plains, and open snow fields.

Terrain Category 2, $Z^{\circ} = 0.02\text{m}$

Open terrain, grassland with few well-scattered obstructions having heights generally from 1.5 to 10.0 metres. This category includes open parkland and sparsely built up outskirts of towns and suburbs.

Terrain Category 3, $Z^{\circ} = 0.2\text{m}$

Terrain with numerous closely spaced obstructions having the size of domestic houses. This includes most suburban areas.

Terrain Category 4, $Z^{\circ} = 2.0\text{m}$

Terrain with numerous large, high (10.0 to 30.0 metres) and close obstructions, such as large city centres and well-developed industrial complexes.

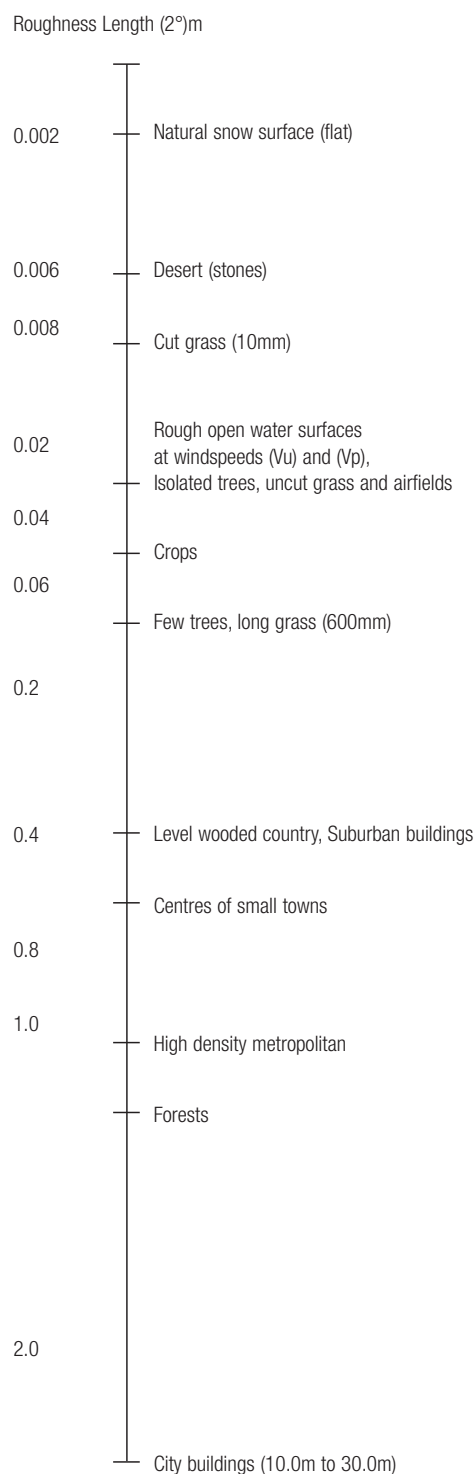
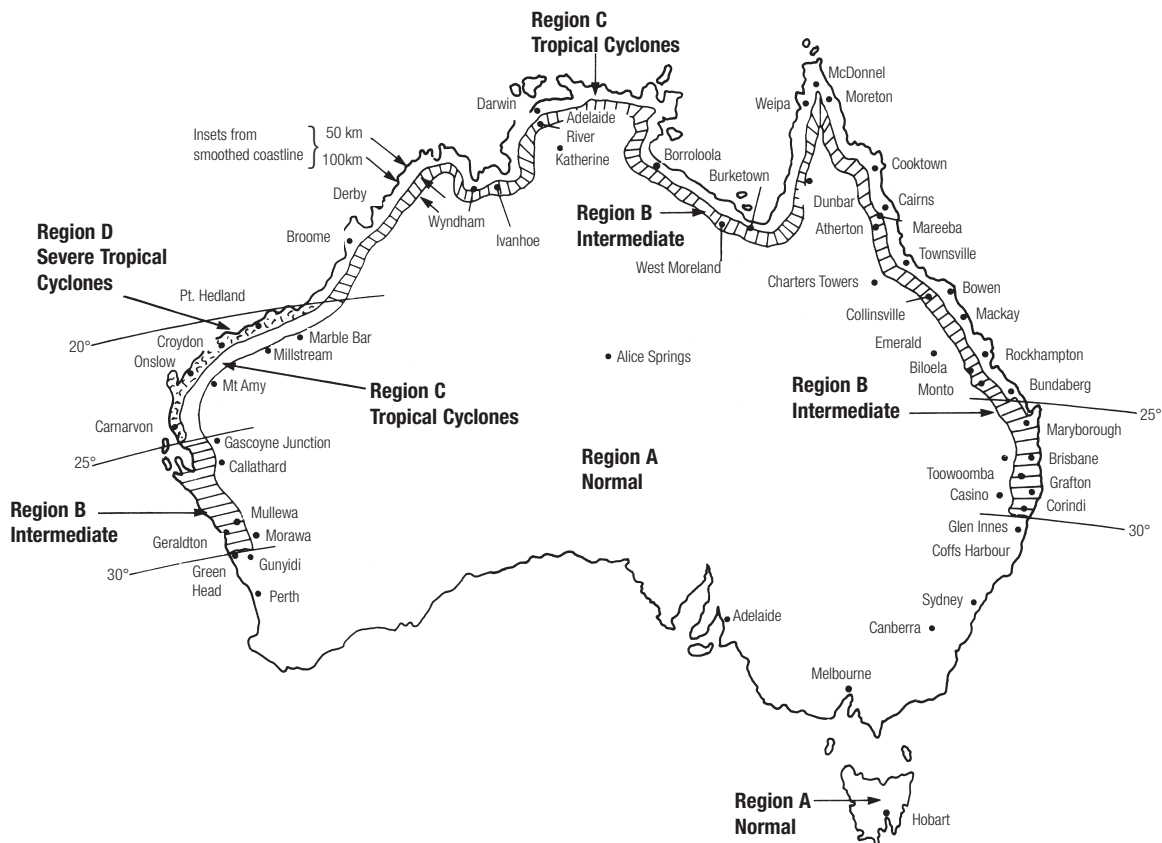

Figure 3: Basic Wind Load Categories

» Design Considerations

Basic Wind Regions



AS/NZS 1170.2 and AS 4055 provides information on wind speeds commonly affecting different areas throughout Australia.

Figure 4: Basic Wind Regions

Table 1: Basic Wind Speed for Ultimate Strength in Different Regions

Region	Wind Classification	Maximum Design Gust Wind Speed (m/s)		
		Permissible Stress (Vp)	Serviceability (Vs)	Ultimate Limit State (Vu)
Non-Cyclonic Regions				
A	N1	28	26	34
A	N2	33	26	40
B	N3	41	32	50
C	N4	50	39	61
Cyclonic Regions				
B	C1	41	32	50
C	C2	50	39	61
D	C3	60	47	74

» Design Considerations

Fixing Tile Roofs in Cyclonic Regions

Flexible pointing shall not be used as the sole mechanical fastening material for ridge and hip caps in C2 and C3 wind areas. A suitable clip, screw or similar fastening device must be used.

Minimum Roof Pitch

LUTUM roof tiles are designed and tested to suit all normal weather conditions. Table 2 indicates minimum roof pitches for LUTUM roof tiles. If there is any doubt regarding roof pitches please refer to your local LUTUM Sales Office.

Table 2: **Minimum Roof Pitch[^]**

Profile	Minimum Pitch (deg) Without Sarking	Minimum Pitch (deg) With Sarking
Concrete NSW, VIC, QLD, ACT		
Macquarie	20	15
Slimline	20	15
Contour*	20	15*
Vogue	x	20
Linea	x	20
Striata	x	20
Concrete SA		
Capri	20	15
Vogue	20	18
Linea	20	18
Striata	20	18
Terracotta (Australia wide)		
French	20	15
Swiss	x	22.5
Designer Ceramic (Australia wide)		
Shingle	20	18
Artline	20	18
Wave	20	18

[^] Maximum rafter length at the minimum pitch is 4.5 metres.

* In Victoria to be laid cross bonded on pitches of 20° and lower

x Not recommended

Maximum Rafter Lengths

The minimum pitch recommended for a roof can be influenced by the water run off depth. Extremely long roof runs accumulate water to a considerable depth at the bottom of the run, particularly at low pitches, and under heavy rainfall conditions. LUTUM recommends that any roof with rafter lengths in excess of 4.5 metres should be installed at a pitch greater than the minimum stated in Table 2. As a general guide the specified pitch should increase by 2° for every additional metre of rafter length.

Maximum Rafter Lengths No Sarking

AS 2050 Installation of roof tiles, item 3.1.5 provides the following information:

Long rafter lengths may require sarking to prevent ingress of rain water into the roof. These lengths may vary according to the tile type, the pitch of the roof and the exposure. The manufacturer's specifications should be consulted. The table below indicates maximum rafter lengths, measured from the topmost point of the rafter downwards, below which sarking shall be installed over the remainder of the rafter.

Table 3: **Sarking Requirements Re Pitch/Rafter Length**

Roof Pitch (deg)	Maximum Rafter Length (mm) Without Sarking
18 < 20	4500
20 < 22	5500
22	6000

» Design Considerations

Sarking

LUTUM always recommends sarking. Sarking provides the ultimate protection against the wet, the heat and the dust, but can only be installed during house construction or a re-roof.

Sarking is mandatory under Australian Standards if:

- Your home is located in an area with a wind classification greater than N3.
- Your home is located in a bushfire prone area.
- The roof pitch is less than or equal to 18 degrees unless stated otherwise.
- Required due to maximum rafter length relative to pitch – refer to Table 3 on page 16.

Certain roof tile profiles also require sarking. Refer to product specification sheets on pages 24-42.

Insulation

The roof and ceiling work together using two types of insulation to stop the transfer of different types of heat: radiant heat from the sun through the tiles; and convection heat through the ceiling.

The number one defence against radiant heat is a non-flammable thin membrane called sarking, also known as reflective insulation or reflective foil laminate (RFL).

Bulk insulation or ceiling batts combat the effects of convection heating from the roof space. Remember while ceiling insulation is easy to retro-fit if the roof space is accessible, sarking can only be installed during construction or re-tiling.



Figure 5: Thermal Loss

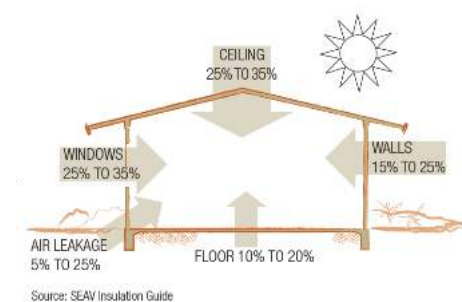

Figure 6: Thermal Gain

Ventilation

Whirly birds work to reduce both heat and moisture in the roof space and is equally important all year-round. Installing whirly birds on opposite sides of the roof space allows for cross-ventilation, which is more beneficial than a single-sided whirly bird as it facilitates greater air movement.

LUTUM Roof Tiles Technical Information Guide

Performance Characteristics



Performance Characteristics

Thermal Performance

Thermal mass, the ability of a material to retain heat, is an important aspect in most Australian climates where there is a need to average out temperatures. High thermal mass materials such as clay and concrete, when used correctly, can result in advantageous heat transmission.

Another consideration to performance is the proportion of solar energy the roof absorbs and reflects, due to the colour of the roof. Refer to LUTUM's Basix colour ratings on page 20.

Note:

Colours have limited impact on thermal performance when elements such as sarking, insulation and ventilation are incorporated.

Acoustic Performance

Typically, external noise penetrates a building through windows, doors, walls and to a lesser extent the roof. Generally the roof would be the least important path of noise transmission though in locations where there are busy roads, railways or aircraft noise the roof becomes an element to be considered.

The density of tiles helps reduce typical external sounds, and has a sound reduction potential twice that of sheet metal roofing.¹

1. "Roof Acoustic Performance - Noise Attenuation", Max Granger, Roof Tile Association of Australia, 2013.

Water Collection

All LUTUM roof tiles are suitable for the safe collection of rain water.

Concrete tiles; only non-toxic surface finishes that comply with the requirements outlined in the Australian Standard 2049 Roof Tiles are used.

Terracotta tiles; once fired are inert bodies and no lead, cadmium or other heavy metals are used in the ceramic glazes.

Note:

- *Consideration is required regarding the types of flashing material used to weatherproof joints on the roof, especially in the collection of potable water from the roof.*
- *Extra precautions such as first flush systems and filters should be considered to remove dust and debris from the collected water.*
- *Guidelines on the safe collection and storage of rain water can be found in "Guidelines on the collection care and control of rainwater in tanks".*
- *A method of assessing compliance is provided by BS6920.*

» Performance Considerations

Table 4: **Tile Energy Efficiency Data**

Tile Colour	Solar Absorptance	Solar Reflectance	Solar Reflectance Index (SRI)	Emittance	Building Code of Australia (BCA)	BASIX
DESIGNER CERAMIC RANGE						
Pearl (Matt)	0.3	0.65	78.4	0.89	Light	Light
Eclipse (Matt)	0.8	0.16	11.5	0.86	Dark	Dark
Eclipse (Satin)	0.9	0.14	10	0.87	Dark	Dark
Slate (Matt)	0.7	0.26	25.4	0.87	Dark	Medium
Slate (Satin)	0.8	0.22	20.2	0.87	Dark	Dark
Sydney Red (Matt)	0.6	0.37	40.3	0.87	Medium	Medium
TERRACOTTA RANGE						
Pearl (Matt)	0.3	0.65	78.4	0.89	Light	Light
Eclipse (Gloss)	0.9	0.05	-1.6	0.87	Dark	Dark
Eclipse (Matt)	0.8	0.16	11.5	0.86	Dark	Dark
Federation (Gloss)	0.7	0.31	32.4	0.87	Dark	Medium
Slate (Gloss)	0.9	0.13	8.1	0.87	Dark	Dark
Slate (Matt)	0.8	0.24	22.4	0.87	Dark	Dark
Sienna Red (Gloss)	0.8	0.22	20.2	0.87	Dark	Dark
Sydney Red (Matt)	0.6	0.37	40.3	0.87	Medium	Medium
CONCRETE RANGE						
Ebony	0.9	0.05	0.2	0.92	Dark	Dark
Charcoal (Colour Through)	0.9	0.07	3.8	0.91	Dark	Dark
Cotton	0.4	0.61	74.3	0.92	Light	Light
Gunmetal	0.9	0.10	6.9	0.92	Dark	Dark
Peat	0.9	0.12	10.3	0.92	Dark	Dark
Quartz	0.6	0.42	47.7	0.91	Medium	Medium
Shale	0.8	0.17	15.6	0.92	Dark	Dark
Twilight	0.9	0.07	3.1	0.92	Dark	Dark
Walnut	0.7	0.27	28.7	0.91	Dark	Medium

» Performance Considerations

Testing: AS 2049 – Roof Tiles

LUTUM conduct regular sampling and testing of both concrete and terracotta tiles during production and prior to dispatch from our various plants.

The test criteria are set out below:

Dimensional Tolerances

A sample of 12 tiles shall be tested. The dimensional tolerances for roof tiles shall be determined in accordance with AS 4046.2.

The mean of the individual results shall be as follows:

- a. Exposed width: manufacturer's nominated width \pm 2%.
- b. Length: manufacturer's nominated length \pm 2%.

Permeability

When tiles are tested in accordance with AS 4046.5, the permeability of each of the three test specimens shall be such that, at the end of 2 hours, no drop of water shall have formed on the underside of any of the test specimens.

Retests are permitted.

Water Absorption

Water absorption; when roof tiles or accessories are tested in accordance with AS 4046.4, the percentage of water absorption of any test pieces shall be no more than 10%.

Transverse Breaking Load

When tested in accordance with AS 4046.3, the average transverse breaking load for the six test specimens shall be not less than 4N per millimetre of exposed width for all tiles. Additionally, the transverse breaking load for each of the individual test specimens shall be not less than 3.325N per millimetre of exposed width for all tiles.

Retests are permitted.

Resistance to Salt Attack

The ability of roof tile units to resist salt attack shall be categorised (see table below) by testing in accordance with AS 4046.7.

Table 5: **Salt Attack Resistance Categories**

Category	Requirement/Description
Exposure Grade	<0.4 g loss in 40 cycles in AS 4046.7 for roof tiles (non-metallic)
General Purpose	Supplier's experience, according to which it is possible to demonstrate that the product has a history of surviving under environmental conditions similar to those existing at the site considered. Products that fit this category are not expected to meet the mass loss criterion for "exposure" grade when tested in accordance with AS 4046.7.

Roof tiles tested in accordance with this Standard, categorised as "exposure" grade shall be deemed suitable in all exposure environments, including severe marine environment.

Note:

Severe marine environment; up to 100m from a non-surf coast and up to 1km from a surf coast are both regarded as severe marine environment. The distances specified are from the mean high water mark.

Testing: AS 2050 - Installation of Roof Tiles

All LUTUM Roof tiles have been subjected to the "Dynamic weather resistance test".

» Performance Considerations

Fire Resistance

All LUTUM roof tiles are noncombustible.

Australian Standard AS 3959-2009: Construction of buildings in bushfire-prone areas specifies the requirements for the construction of buildings in bushfire-prone areas in order to improve their resistance to bushfire attack from burning embers, radiant heat, flame contact and combinations of the three attack forms. One of the main objectives of the Standard is to increase the chances of a building surviving while a fire front passes.

Building sites assessed under AS 3959-2009 as BAL-FZ are those sites considered to be most at risk of bushfire attack. In this zone, there is an extremely high risk of ember attack and burning debris ignited by windborne embers, and a likelihood of exposure to an extreme level of radiant heat and direct exposure to flames.

LUTUM Roof tiles when used in conjunction with sarking (sarking to be rated Low and cover the entire roof) form an acceptable method of roof covering where construction in accordance with AS 3959 Construction of buildings in bushfire-prone areas is required.

For more information refer to the Roofing Tile Association of Australia. "Building With Tiled Roofs in Bushfire Prone Areas".

Note:

Extreme winds can be generated during bushfires. Fixing requirements should be increased as a precaution against the higher wind classification.

Due to external factors, ie vegetation management, the unpredictable nature and behaviour of fire, and extreme weather conditions; it should be borne in mind that LUTUM cannot guarantee that a building will survive a bushfire event.

LUTUM Roof Tiles Technical Information Guide

Terracotta Roof Tiles

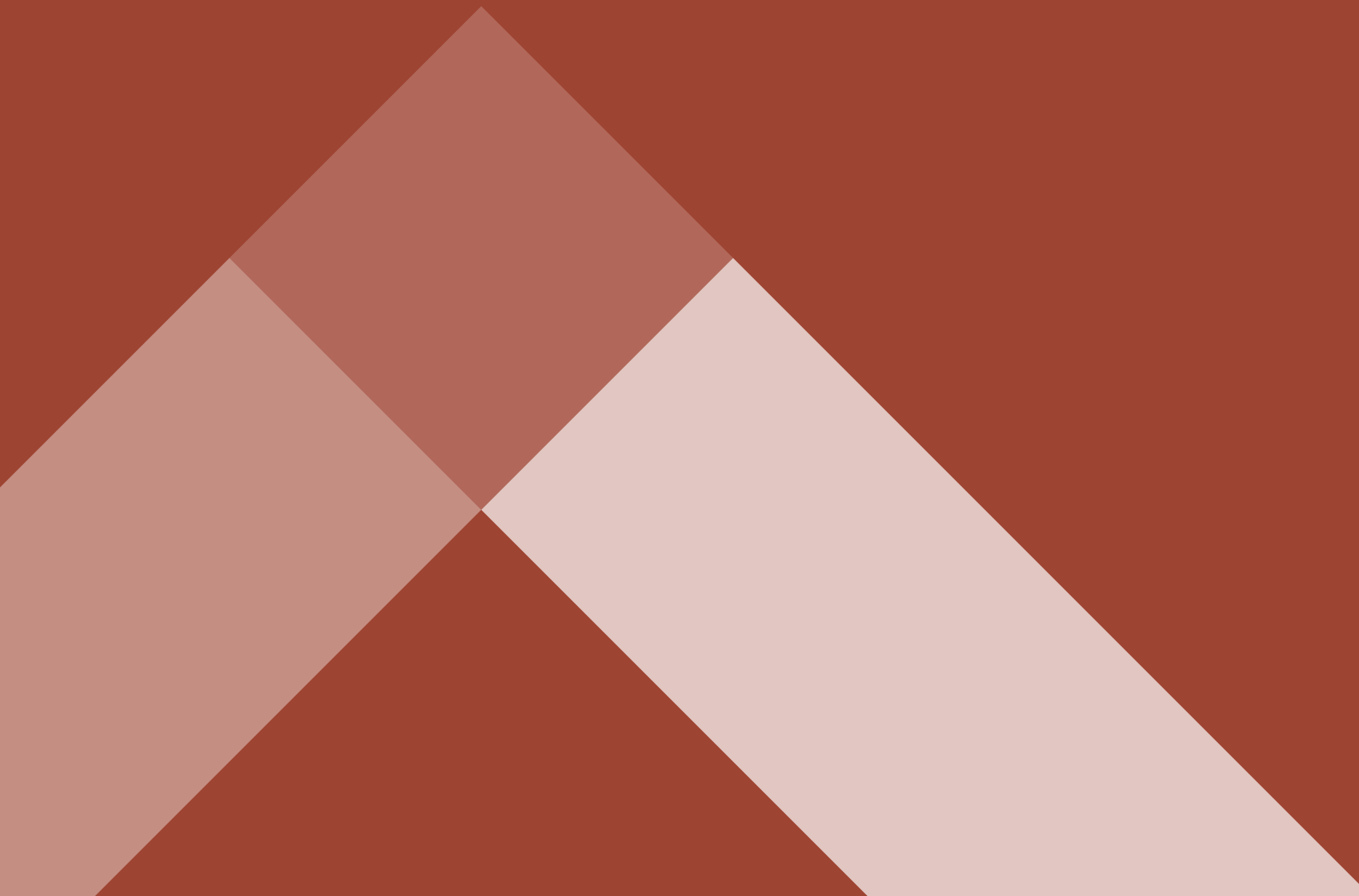

Terracotta Roof Tiles

French™

The French Terracotta roof tiles unique two valley shape gives the roof line a look of texture and flow. It will give your home a look of refinement and classical style and is ideal for both rural and city living.

French Terracotta roof tiles interlock at the head and side lap and are laid in a cross bond pattern. To ensure maximum weather proofing the nail hole for tile fixing has been designed in the batten lug on the underside of the tile and is unique to LUTUM.

For further fixing details refer to Roof Installation Section.

Product Specification

French™		
Coverage	No of tiles per sq m	12.3 (mean)
Dimensions (Nominal)	Actual length:	423mm
	Actual width:	265mm
	Exposed length:	350mm (mean)
	Exposed width:	236mm
Mass (Nominal)	Mass per tile:	3.1kg
	Mass per sq m:	37.2kg
Minimum Roof Pitch	15° with sarking and 20° without sarking	
Set Out (Nominal)	Batten spacing:	337mm min – 362mm max
	It is good tiling practice to check the gauge of all kiln fired clay roof tiles at the site.	
First Course	Batten spacing:	310mm on 38mm x 38mm battens
Recommended Bond	Cross Bond	
Availability	National	



French™



Cross section

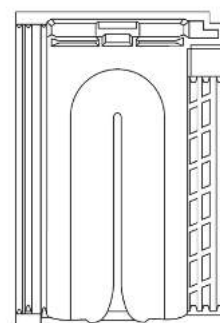

Plan view

» Terracotta Roof Tiles

Swiss™

Based on a bold European design, the Swiss Terracotta roof tile is ideal for modern and Mediterranean style homes, and is as durable as it is stylish.

Swiss terracotta roof tiles interlock at the head and side lap and are laid in a straight bond pattern. To ensure maximum weather proofing the nail hole for tile fixing has been designed in the batten lug on the underside of the tile and is unique to LUTUM.

For further fixing details refer to Roof Installation Section.

Product Specification

Swiss™

Coverage	No of tiles per sq m	13.2
Dimensions (Nominal)	Actual length:	418mm
	Actual width:	260mm
	Exposed length:	355mm
	Exposed width:	214mm
Mass (Nominal)	Mass per tile:	3.2kg
	Mass per sq m:	43.84kg
Minimum Roof Pitch	22.5° with sarking	
Set Out (Nominal)	Batten spacing:	355mm
	It is good tiling practice to check the gauge of all kiln fired clay roof tiles at the site.	
First Course	Batten spacing:	295mm on 38mm x 38mm battens
Recommended Bond	Straight Bond	
Availability	National	



Swiss™

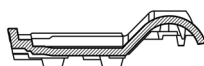

Cross section

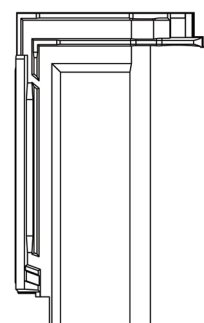

Plan view

LUTUM Roof Tiles Technical Information Guide

Designer Ceramic Roof Tiles



Designer Ceramic Roof Tiles

Artline®

The designer range is elegant and shaped for design flexibility. Uniquely striking, with colour integrity and low maintenance. These state-of-the-art tiles offer an exclusive streamlined look, with minimalist textures that compliment a modern home.

Product Specification

Artline®		
Coverage	No of tiles per sq m	14.3
Dimensions (Nominal)	Actual length:	425mm
	Actual width:	264mm
	Exposed length:	308mm
	Exposed width:	226mm
Mass (Nominal)	Mass per tile:	3.30kg
	Mass per sq m:	47.19kg
Minimum Roof Pitch	18° with sarking and 20° without sarking	
Set Out (Nominal)	Batten spacing:	308mm
	It is good tiling practice to check the gauge of all kiln fired clay roof tiles at the site.	
First Course	Batten spacing:	308mm on 38mm x 38mm battens
Recommended Bond	Cross Bond	
Availability	National	



Artline®

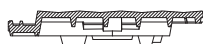

Cross section

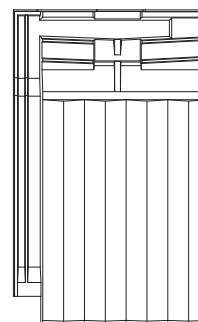

Plan view

» Designer Ceramic Roof Tiles

Shingle™

The designer range is elegant and shaped for design flexibility. Uniquely striking, with colour integrity and low maintenance. These state-of-the-art tiles offer an exclusive streamlined look, with minimalist textures that compliment a modern home.

Product Specification

Shingle™		
Coverage	No of tiles per sq m	14.3
Dimensions (Nominal)	Actual length:	425mm
	Actual width:	264mm
	Exposed length:	308mm
	Exposed width:	226mm
Mass (Nominal)	Mass per tile:	3.30kg
	Mass per sq m:	47.19kg
Minimum Roof Pitch	18° with sarking and 20° without sarking	
Set Out (Nominal)	Batten spacing:	308mm
	It is good tiling practice to check the gauge of all kiln fired clay roof tiles at the site.	
First Course	Batten spacing:	308mm on 38mm x 38mm battens
Recommended Bond	Cross Bond	
Availability	National	



Shingle™

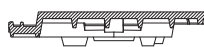

Cross section

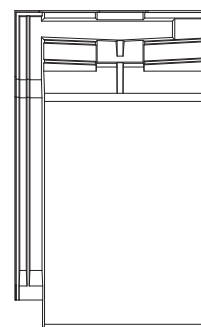

Plan view

» Designer Ceramic Roof Tiles

Wave™

The designer range is elegant and shaped for design flexibility. Uniquely striking, with colour integrity and low maintenance. These state-of-the-art tiles offer an exclusive streamlined look, with minimalist textures that compliment a modern home.

Product Specification

Wave™		
Coverage	No of tiles per sq m	14.3
Dimensions (Nominal)	Actual length:	425mm
	Actual width:	264mm
	Exposed length:	308mm
	Exposed width:	226mm
Mass (Nominal)	Mass per tile:	3.30kg
	Mass per sq m:	47.19kg
Minimum Roof Pitch	18° with sarking and 20° without sarking	
Set Out (Nominal)	Batten spacing:	308mm
	It is good tiling practice to check the gauge of all kiln fired clay roof tiles at the site.	
First Course	Batten spacing:	308mm on 38mm x 38mm battens
Recommended Bond	Cross Bond	
Availability	National	



Wave™

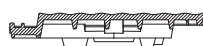

Cross section

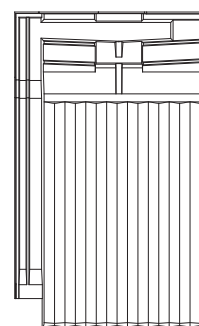

Plan view

LUTUM Roof Tiles Technical Information Guide

Concrete Roof Tiles



Concrete Roof Tiles

Capri™ SA

The Capri roof tiles low, round shape make it an ideal choice for a wide range of classic, colonial and conventional home designs.

Product Specification

Capri™ SA		
Coverage	No of tiles per sq m	10.5
Dimensions (Nominal)	Actual length:	432mm
	Actual width:	315mm
	Exposed length:	342mm
	Exposed width:	280mm
Mass (Nominal)	Mass per tile:	5.2kg
	Mass per sq m:	54.30kg
Minimum Roof Pitch	15° with sarking and 20° without sarking	
Set Out (Nominal)	Batten spacing:	342mm max
First Course	Batten spacing:	315mm (using a 38mm wide batten)
Head Lap	Minimum head lap shall be 90mm. This may increase according to set out. However, head lap should not exceed 100mm.	
Recommended Bond	Cross Bond	
Availability	SA	

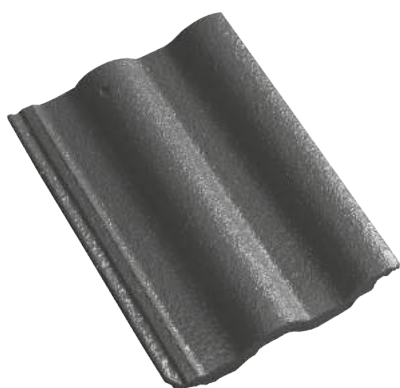

Cross section

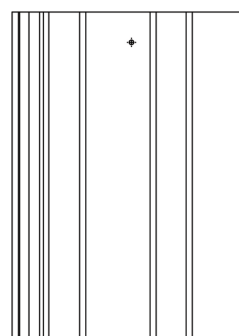

Plan view

Capri™ SA

» Concrete Roof Tiles

Contour™ NSW, VIC, QLD, ACT

The subtle shaped profile of Contour, with its soft undulating curves, combines enduring design with the distinctive quality of individual tiles.

Product Specification

Contour™ NSW, VIC, QLD, ACT

Coverage	No of tiles per sq m	9.4
Dimensions (Nominal)	Actual length:	432mm
	Actual width:	345mm
	Exposed length:	355mm
	Exposed width:	300mm
Mass (Nominal)	Mass per tile:	5.2kg
	Mass per sq m:	48.88kg
Minimum Roof Pitch	15° with sarking and 20° without sarking (in VIC to be laid cross bonded on pitches of 20°)	
Set Out (Nominal)	Batten spacing:	355mm
Head Lap	Minimum head lap shall be 75mm. This may increase according to set out. However, head lap should not exceed 120mm.	
First Course	Batten spacing:	315mm (using a 38mm wide batten)
Recommended Bond	Cross Bond, Straight Bond (Cross Bond recommended at roof pitch less than 20°).	
Availability	NSW, ACT & VIC	



Cross section

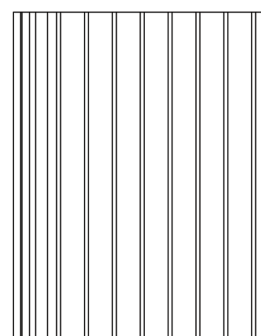

Plan view

Contour™ NSW, ACT & VIC

» Concrete Roof Tiles

Linea™ NSW, ACT & QLD

The Linea tile is a cost effective alternative to the traditional slate shingle, which gives a distinct, clean sweeping look to any house design.

Made of durable concrete, each tile is a rugged performer against heat, wind and rain. Linea roof tiles are colour-through, which means the colour goes throughout the body of the tile, not just the surface.

Product Specification

Linea™ NSW, ACT & QLD		
Coverage	No of tiles per sq m	9.4
Dimensions (Nominal)	Actual length:	432mm
	Actual width:	345mm
	Exposed length:	355mm
	Exposed width:	300mm
Mass (Nominal)	Mass per tile:	5.55kg
	Mass per sq m:	52.2kg
Minimum Roof Pitch	20° with sarking	
Set Out (Nominal)	Batten spacing:	355mm max
First Course	Batten spacing:	315mm (using a 38mm wide batten)
Head Lap	Minimum head lap shall be 75mm. This may increase according to set out. However, head lap should not exceed 120mm.	
Recommended Bond	Quarter Bond	
Availability	NSW, ACT & QLD	

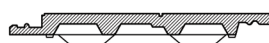

Cross section

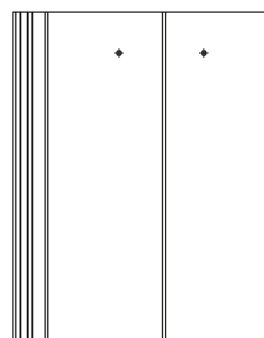

Plan view

Linea™ NSW, ACT & QLD

» Concrete Roof Tiles

Linea™ SA

The Linea tile is a cost effective alternative to the traditional slate shingle, which gives a distinct, clean sweeping look to any house design. Made of durable concrete, each tile is a rugged performer against heat, wind and rain. Linea roof tiles are colour-through, which means the colour goes throughout the body of the tile, not just the surface.

Product Specification

Linea™ SA		
Coverage	No of tiles per sq m	10.8
Dimensions (Nominal)	Actual length:	432mm
	Actual width:	315mm
	Exposed length:	342mm
	Exposed width:	280mm
Mass (Nominal)	Mass per tile:	5.55kg
	Mass per sq m:	57.95kg
Minimum Roof Pitch	18° with sarking; 20° without sarking	
Set Out (Nominal)	Batten spacing:	342mm max
First Course	Batten spacing:	315mm (using a 38mm wide batten)
Head Lap	Minimum head lap shall be 90mm. This may increase according to set out. However, head lap should not exceed 120mm.	
Recommended Bond	Cross Bond	
Availability	SA	



Linea™ SA

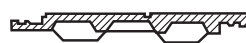

Cross section

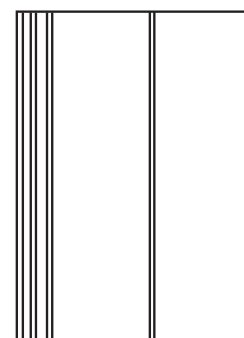

Plan view

» Concrete Roof Tiles

Linea™ VIC

The Linea tile is a cost effective alternative to the traditional slate shingle, which gives a distinct, clean sweeping look to any house design.

Made of durable concrete, each tile is a rugged performer against heat, wind and rain. Linea roof tiles are colour-through, which means the colour goes throughout the body of the tile, not just the surface.

Product Specification

Linea™ VIC		
Coverage	No of tiles per sq m	9.4
Dimensions (Nominal)	Actual length:	432mm
	Actual width:	345mm
	Exposed length:	342mm
	Exposed width:	300mm
Mass (Nominal)	Mass per tile:	5.55kg
	Mass per sq m:	54.00kg
Minimum Roof Pitch	20° with sarking	
Set Out (Nominal)	Batten spacing:	342mm max
First Course	Batten spacing:	315mm (using a 38mm wide batten)
Head Lap	Minimum head lap shall be 90mm. This may increase according to set out. However, head lap should not exceed 120mm.	
Recommended Bond	Quarter Bond	
Availability	VIC	

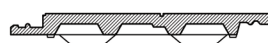

Cross section

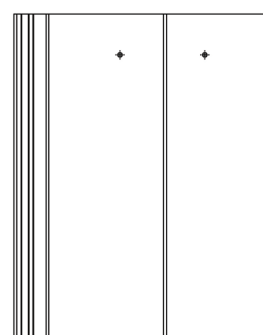

Plan view

Linea™ VIC

» Concrete Roof Tiles

Macquarie™ NSW, ACT, QLD & VIC

The Macquarie features a low, double curve profile designed to match the character and style of Australian homes. Beautiful, strong and durable, Macquarie is one of our most popular tiles.

Product Specification

Macquarie™ NSW, ACT, QLD & VIC		
Coverage	No of tiles per sq m	9.2
Dimensions (Nominal)	Actual length:	432mm
	Actual width:	343mm
	Exposed length:	355mm
	Exposed width:	308mm
Mass (Nominal)	Mass per tile:	4.65kg
	Mass per sq m:	42.8kg
Minimum Roof Pitch	15° with sarking and 20° without sarking	
Set Out (Nominal)	Batten spacing:	355mm
Head Lap	Minimum head lap shall be 75mm. This may increase according to set out. However, head lap should not exceed 120mm.	
First Course	Batten spacing:	315mm (using a 38mm wide batten)
Recommended Bond	Straight Bond / Cross Bond	
Availability	NSW, ACT, QLD & VIC	



Cross section

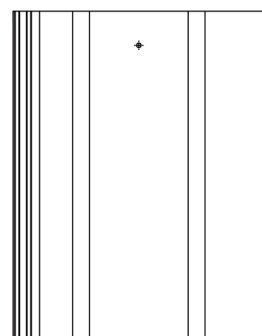

Plan view

Macquarie™ NSW, ACT, QLD & VIC

» Concrete Roof Tiles

Slimline™ NSW, ACT, QLD & VIC

Innovative. Bold. Modern. The Slimline's unique design is right at home on Australia's most progressive structures.

Product Specification

Slimline™ NSW, ACT, QLD & VIC

Coverage	No of tiles per sq m	9.2
Dimensions (Nominal)	Actual length:	432mm
	Actual width:	336mm
	Exposed length:	355mm
	Exposed width:	308mm
Mass (Nominal)	Mass per tile:	4.8kg
	Mass per sq m:	44.16kg
Minimum Roof Pitch	15° with sarking and 20° without sarking	
Set Out (Nominal)	Batten spacing:	355mm max
First Course	Batten spacing:	315mm (using a 38mm wide batten)
Head Lap	Minimum head lap shall be 75mm. This may increase according to set out. However, head lap should not exceed 120mm.	
Recommended Bond	Straight Bond / Cross Bond	
Availability	NSW, ACT, QLD and VIC	

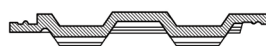

Cross section

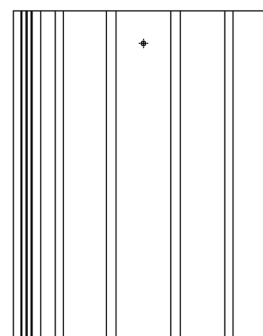

Plan view

Slimline™ NSW, ACT, QLD & VIC

» Concrete Roof Tiles

Striata™ SA

Striata's clean, simple design, together with a unique striated surface, makes it a popular choice.

Product Specification

Striata™ SA		
Coverage	No of tiles per sq m	10.8
Dimensions (Nominal)	Actual length:	432mm
	Actual width:	315mm
	Exposed length:	342mm
	Exposed width:	280mm
Mass (Nominal)	Mass per tile:	5.3kg
	Mass per sq m:	55.33kg
Minimum Roof Pitch	18° with sarking; 20° without sarking	
Set Out (Nominal)	Batten spacing:	342mm
First Course	Batten spacing:	315mm (using a 38mm wide batten)
Head Lap	Minimum head lap shall be 90mm. This may increase according to set out. However, head lap should not exceed 110mm.	
Recommended Bond	Cross Bond	
Availability	SA	



Striata™ SA



Cross section

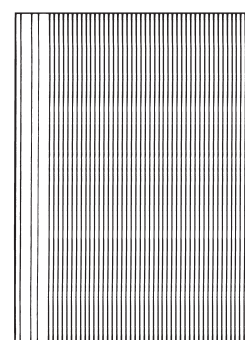

Plan view

» Concrete Roof Tiles

Striata™ VIC

Striata's clean, simple design, together with a unique striated surface, makes it a popular choice.

The Striata is available with colour-through and with colour-on.

Product Specification

Striata™ VIC		
Coverage	No of tiles per sq m	9.4
Dimensions (Nominal)	Actual length:	432mm
	Actual width:	345mm
	Exposed length:	342mm
	Exposed width:	300mm
Mass (Nominal)	Mass per tile:	5.5kg
	Mass per sq m:	53.60kg
Minimum Roof Pitch	20° with sarking	
Set Out (Nominal)	Batten spacing:	342mm max
First Course	Batten spacing:	315mm (using a 38mm wide batten)
Head Lap	Minimum head lap shall be 90mm. This may increase according to set out. However, head lap should not exceed 120mm.	
Recommended Bond	Cross Bond	
Availability	VIC	



Cross section

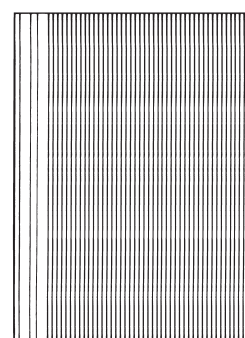

Plan view

Striata™ VIC

» Concrete Roof Tiles

Vogue™ NSW, ACT & QLD

Fashionably flat, Vogue strikes at the heart of contemporary style. With alluring clean lines and modern colours, it's a new level of curb-side attraction.

Product Specification

Vogue™ NSW, ACT & QLD

Coverage	No of tiles per sq m	9.4
Dimensions (Nominal)	Actual length:	432mm
	Actual width:	345mm
	Exposed length:	355mm
	Exposed width:	300mm
Mass (Nominal)	Mass per tile:	5.2kg
	Mass per sq m:	48.9kg
Minimum Roof Pitch	20° with sarking	
Set Out (Nominal)	Batten spacing:	355mm
Head Lap	Minimum head lap shall be 75mm. This may increase according to set out. However, head lap should not exceed 120mm.	
First Course	Batten spacing:	315mm (using a 38mm wide batten)
Recommended Bond	Cross Bond	
Availability	NSW, ACT & QLD	



Vogue™ NSW, ACT & QLD

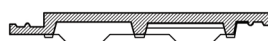

Cross section

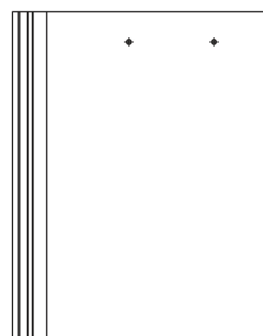

Plan view

» Concrete Roof Tiles

Vogue™ SA

Fashionably flat, Vogue strikes at the heart of contemporary style. With alluring clean lines and modern colours, it's a new level of curb-side attraction.

Product Specification

Vogue™ SA		
Coverage	No of tiles per sq m	10.8
Dimensions (Nominal)	Actual length:	432mm
	Actual width:	315mm
	Exposed length:	342mm
	Exposed width:	280mm
Mass (Nominal)	Mass per tile:	5.55kg
	Mass per sq m:	57.95kg
Minimum Roof Pitch	18° with sarking; 20° without sarking	
Set Out (Nominal)	Batten spacing:	342mm max
First Course	Batten spacing:	315mm (using a 38mm wide batten)
Head Lap	Minimum head lap shall be 90mm. This may increase according to set out. However, head lap should not exceed 120mm.	
Recommended Bond	Cross Bond	
Availability	SA	



Vogue™ SA

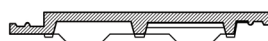

Cross section

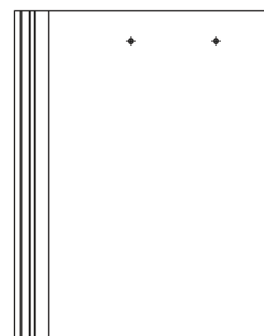

Plan view

» Concrete Roof Tiles

Vogue™ VIC

Fashionably flat, Vogue strikes at the heart of contemporary style. With alluring clean lines and modern colours, it's a new level of curb-side attraction.

Product Specification

Vogue™ VIC		
Coverage	No of tiles per sq m	9.4
Dimensions (Nominal)	Actual length:	432mm
	Actual width:	345mm
	Exposed length:	342mm
	Exposed width:	300mm
Mass (Nominal)	Mass per tile:	5.5kg
	Mass per sq m:	53.60kg
Minimum Roof Pitch	20° with sarking	
Set Out (Nominal)	Batten spacing:	342mm max
First Course	Batten spacing:	315mm (using a 38mm wide batten)
Head Lap	Minimum head lap shall be 90mm. This may increase according to set out. However, head lap should not exceed 120mm.	
Recommended Bond	Cross Bond	
Availability	VIC	

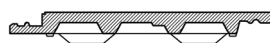

Cross section

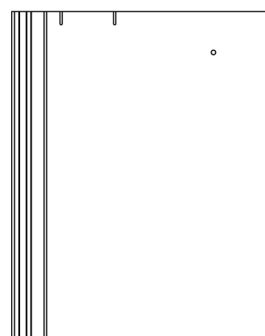

Plan view

Vogue™ VIC

LUTUM Roof Tiles Technical Information Guide

Accessories



Terracotta Accessories

Ridge and Hip Tiles

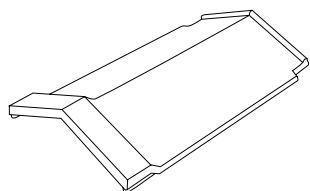

Vee Ridge (130°)
 Dimensions: 435L x 265W x 88D
 Cover length: 400

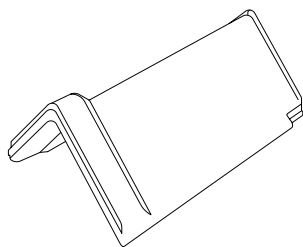

Steep Pitch Vee Ridge (81°)
 For roofs over 45° in pitch
 Dimensions: 430L x 265W x 185D
 Cover length: 400

Ridge and Hip Accessories

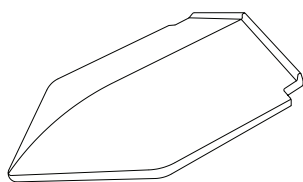

Vee Ridge Shell End (130°)
 Dimensions: 435L x 265W x 70D
 Cover length: 420

Apex Tiles

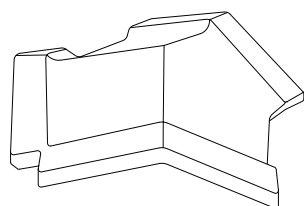

Vee Ridge Three Way Apex (130°)
 Dimensions: 265W x 85D

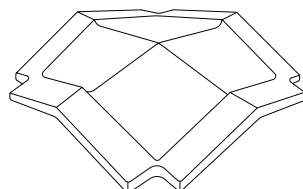

Vee Ridge Four Way Apex (130°)
 Dimensions: 365W x 85D

All dimensions are in millimetres.

» Terracotta Accessories

Apex Tiles

Spoon Apex

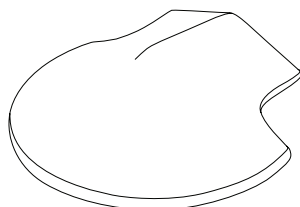

Spoon Apex
For closing multiple junctions

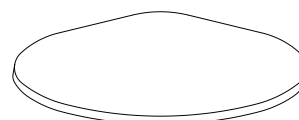

Apex Hat (130°)
Diameter: 450
Height: 100

Barge Tiles

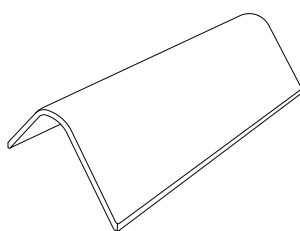

Universal Tapered Barge Capping
Dimensions: 430L x 140D
Cover length: 1 length per tile

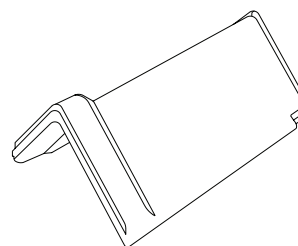

Steep Pitch Vee Ridge (81°)
For roofs over 45° in pitch
Dimensions: 430L x 265W x 185D
Cover length: 400

Crests and Finials

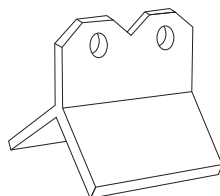

Ridge Crest (130°)
Dimensions: 150L x 245W x 130D

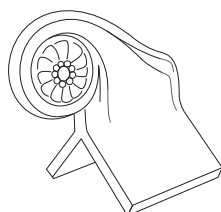

Gable Finial (130°)
Dimensions: 430L x 250W x 265D
Cover length: 400

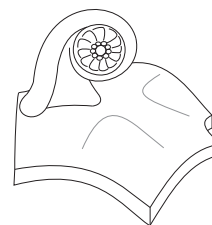

Three Way Apex Finial (130°)
Dimensions: 430L x 440W x 300D

All dimensions are in millimetres.

Designer Ceramic Accessories

Ridge and Hip Tile

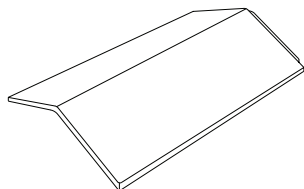

Accent Ridge (130°)
Dimensions: 435L x 265W x 75D
Cover length: 415

Ridge and Hip Accessory

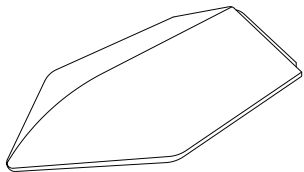

Accent Shell End (130°)
Dimensions: 435L x 265W x 70D
Cover Length: 420

All dimensions are in millimetres.

Concrete Accessories

Ridge and Hip Tiles

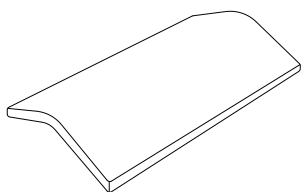

Standard Ridge (130°)
 Dimensions: 430L x 250W x 85D
 Cover length: 400

Barge Tiles

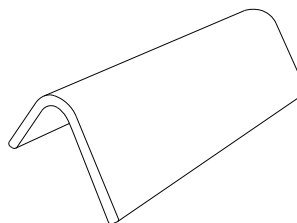

Barge Capping (76°)
 Gable end cover tile
 Dimensions: 430L x 220W x 140D
 Cover length: 1 length per tile

Apex tiles

Ridge Apex

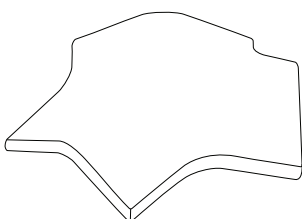

Three Way Apex (130°)
 Dimensions: 430L x 440W x 85D

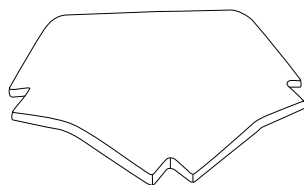

Four Way Apex (130°)
 Dimensions: 370W x 140D

General Accessories

Roof Tile Clips

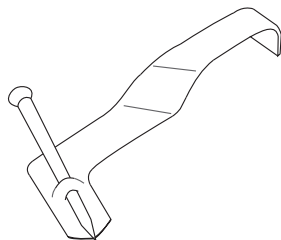

Nail in Side Lap Clip (FCTNSCSI)
Suit Swiss Terracotta roof tiles.

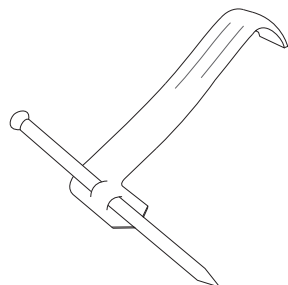

Nail in Side Lap Clip (FCCNSCP)
Suit Macquarie, Slimline, French and Shingle roof tiles.

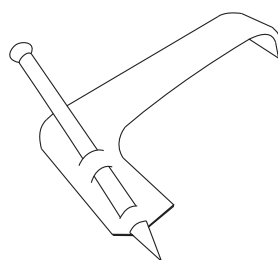

Nail in Side Lap Clip (FTCCNSCFL)
Suit Vogue, Linea and Striata roof tiles.

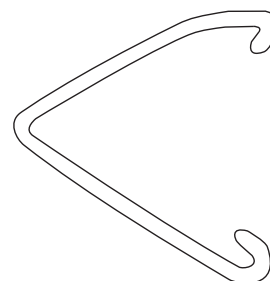

Spring Wire Side Lap Clip
Clip-on head clip, for hardwood and softwood battens.
Available to suit various profiles and batten sizes.

LUTUM clips are available for LUTUM concrete and terracotta roof tiles. Manufactured from corrosion resistant galvanised steel. LUTUM roof tile clips are suitable for both timber and metal battens.

General Accessories

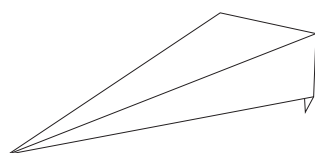

Galvanised Hip End Tray
Adjustable to any pitch supports the Shell End and cut tiles at hip ends.

LUTUM also maintains stocks of:
Battens, Sarking, Anti-ponding board and accessories.

LUTUM Roof Tiles Technical Information Guide

Installation Details



Installation Details

Preparation for Installation

General

The specifier should ensure that the roof structure complies with all relevant local and state statutory requirements and standards where applicable. Particular attention must be paid to the structure to ensure that it is square and straight and properly braced.

This stage of the construction is critically important where roof tiles are used as the slightest deviation from a plain surface will be noticeable on a finished roof and cannot be corrected by the tiler.

Inspection of product for transportation damage should be done upon receipt. If there is any visible damage, a claim should be filed promptly against the carrier.

Examine each pallet for colour, profile and damage. Check accessory items for proper colour, profile and damage. If there is damage to the tile or quantities delivered are not correct, please notify LUTUM or your local distributor immediately.

Suitable areas of the building sites should be made available and access should preferably be provided to all sides of the roof from these stacking locations in order to ensure the most efficient roof loading procedures.

Tile Set Out

LUTUM roof tiles are designed to be consistent in dimension and set out, the design allowing some tolerance in set out to assist the roof tiler. It is recommended however, that designers should ensure that the rafter lengths be designed in order to avoid the cutting of roof tiles at the ridge line, eaves and gables. See diagram below.

Tile Set Out (Terracotta and Concrete)

Tile set out should be to specifications provided by LUTUM for each tile profile. Please contact your state LUTUM Sales Office for details.

See Tile Set Out diagram below for set out measurement points.

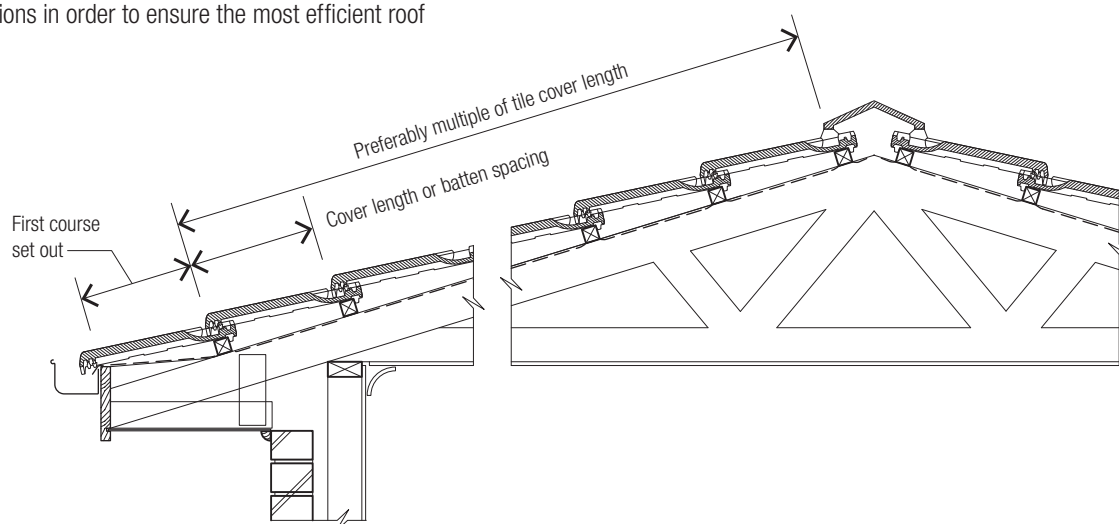

Figure 7: **Tile Set Out**

» Installation Details

How to apply LUTUM Batten Gauge Ready Reckoner

(a) Concrete tiles

- First set out nail to be fixed from front edge of fascia.
 - when using 38 x 38mm battens = 315mm
 - when using 38 x 50mm battens = 303mm
 - when using Top Span 20 battens = 328mm
 Top set out nail to be fixed down from centre of ridge board or truss.
 - when using 38 x 25mm battens = 50mm
 - when using 38 x 38mm battens = 50mm
 - when using 50 x 25mm battens = 62mm
 - when using Top Span 20 battens = 35mm
- Measure distance between bottom and top setout nails.
- Look up this measurement on Ready Reckoner or find batten gauge. Eg Rafter length of 4.550 then batten gauge is 0.350 and number of adjustable courses is 13.

Table 6: Concrete Tile Batten Gauge

Tile Courses	Batten Gauge (mm)						
	330 100 lap	335	340	345	350	355	357 75 lap
First	315	315	315	315	315	315	315
2	645	650	655	660	665	670	672
3	975	985	995	1005	1015	1025	1029
4	1305	1320	1335	1350	1365	1380	1386
5	1635	1655	1675	1695	1715	1735	1743
6	1965	1990	2015	2040	2065	2090	2100
7	2295	2325	2355	2385	2415	2445	2457
8	2625	2660	2695	2730	2765	2800	2814
9	2955	2995	3035	3075	3115	3155	3171
10	3285	3330	3375	3420	3465	3510	3528
11	3615	3665	3715	3765	3815	3865	3885
12	3945	4000	4055	4110	4165	4220	4242
13	4275	4335	4395	4455	4515	4575	4599
14	4605	4670	4735	4800	4865	4930	4956
15	4935	5005	5075	5145	5215	5285	5313
16	5265	5340	5415	5490	5565	5640	5670
17	5595	5675	5755	5835	5915	5995	6027
18	5925	6010	6095	6180	6265	6350	6384
19	6255	6345	6435	6525	6615	6705	6741
20	6585	6680	6775	6870	6965	7060	7098
21	6915	7015	7115	7215	7315	7415	7455
22	7245	7350	7455	7560	7665	7750	7812
23	7575	7685	7795	7905	8015	8085	8169
24	7905	8020	8135	8250	8365	8420	8526
25	8235	8355	8475	8595	8715	8775	8883

 Sarking as required AS 2050 Installation of Roof Tiles.

» Installation Details

LUTUM, Batten Gauge Ready Reckoner

(b) Terracotta Tiles

Table 7: Terracotta Tile Batten Gauge / Rafter Length (mm)

Courses	Shingle Profile	Swiss Profile	French Profile					
	Batten Gauge (mm)							
	308	355	Min 337	342	347	352	357	Max 362
First	308	295	310	310	310	310	310	310
2	616	650	647	652	657	662	667	672
3	924	1005	984	994	1004	1014	1024	1034
4	1232	1360	1321	1336	1351	1366	1381	1396
5	1540	1715	1658	1678	1698	1718	1738	1758
6	1848	2070	1995	2020	2045	2070	2095	2120
7	2156	2425	2332	2362	2392	2422	2452	2482
8	2464	2780	2669	2704	2739	2774	2809	2844
9	2772	3135	3006	3046	3086	3126	3166	3206
10	3080	3490	3343	3388	3433	3478	3523	3568
11	3388	3845	3680	3730	3780	3830	3880	3930
12	3696	4200	4017	4072	4127	4182	4237	4292
13	4004	4555	4354	4414	4474	4534	4594	4654
14	4312	4910	4691	4756	4821	4886	4951	5016
15	4620	5265	5028	5098	5168	5238	5308	5378
16	4928	5620	5365	5440	5515	5590	5665	5740
17	5236	5975	5702	5782	5862	5942	6022	6102
18	5544	6330	6039	6124	6209	6294	6379	6464
19	5852	6685	6376	6466	6556	6646	6736	6826
20	6160	7040	6713	6808	6903	6998	7093	7188
21	6468	7395	7050	7150	7250	7350	7450	7550
22	6776	7750	7387	7492	7597	7702	7807	7912
23	7084	8105	7724	7834	7944	8054	8164	8274
24	7392	8460	8061	8176	8291	8406	8521	8636
25	7700	8815	8398	8518	8638	8758	8878	8998

 Sarking as required AS 2050 Installation of Roof Tiles.

» Installation Details

Counter Battens

Counter Battens are needed when the design calls for lining on top of the rafters such as raked ceilings or exposed rafters. In these circumstances a counter batten is fastened to the rafter through the ceiling lining (sarking must be used with raked or close boarded ceiling),

AS NZS 4200-2.

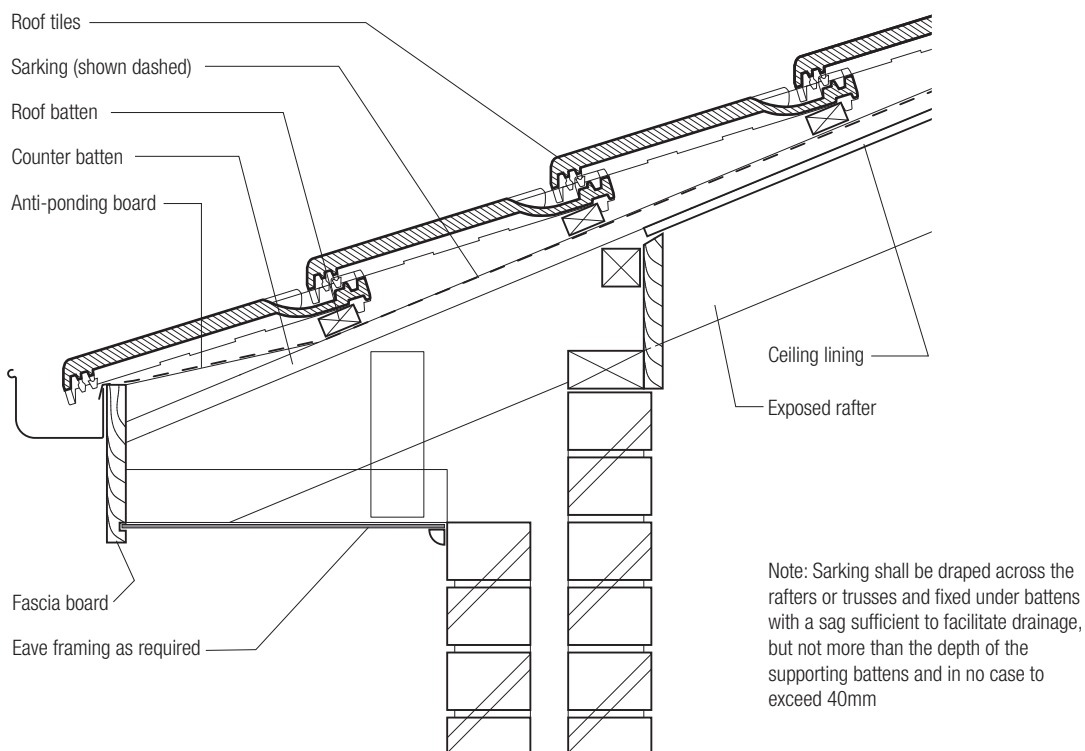

Figure 8: Counter Batten Detail

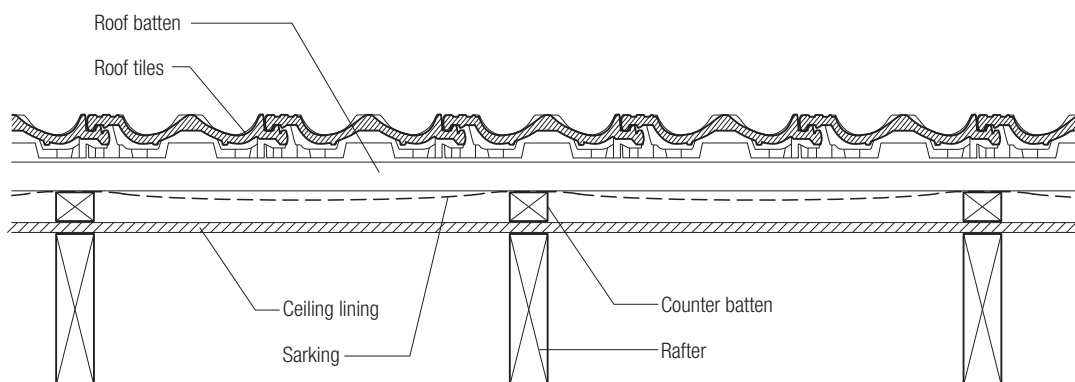

Figure 9: Counter Batten Detail

» Installation Details

Recommended Batten Sizes and Types

Batten sizes and types vary by region throughout Australia, depending on local practice, rafter spacing, timber availability etc. The following table summarises suitable batten types and current practices. It is recommended that local authorities be consulted before final specification of battens and requirements may vary. Battens that are warped, twisted, of uneven dimension, or excessively knotty, should not be used. Where steel battens are to be used, refer to the batten suppliers technical information.

Table 8: **Batten Sizes and Rafter Spacings** (mm)

States	Rafter Spacing					
	450mm S/wood	450mm H/wood	600mm S/wood	600mm H/wood	900mm S/wood	900mm H/wood
NSW	38 x 28	38 x 25	38 x 38	38 x 25	63 x 38	50 x 38
ACT	38 x 28	38 x 25 50 x 25	38 x 38	38 x 25 50 x 25	63 x 38	50 x 38
VIC		50 x 25	38 x 38	50 x 25		50 x 38
SA	21mm steel battens up to 600mm rafter spacings only					
TAS		50 x 25		50 x 25		50 x 38

Batten Installation

Battens should be aligned within a tolerance of ± 2 mm in 4m. Joints in battens must be cut over the centre of the rafter or top chord and nailed. Batten joints should be staggered over the roof so that no two consecutive battens are joined on the same rafter.

Battens are to be nailed at each rafter intersection. The nails are to penetrate the rafter to a depth of at least 10 times the diameter of the specified nail. (See appendix C Australian Standard 2050 for Acceptable nail sizes.)

At valleys or hips, battens should be cut and nailed into the valley or hip boards in a manner, which provides a firm support for the weight of the laid tiles.

Valleys

Valley boards and irons should be installed with enough depth in the valley iron so that it finishes level with the top of the roof batten when this is later installed.

Valley boards should be at least 19mm thick and should be laid over the ends of the rafters where they join to valley rafters.

Where there is a change in direction of a valley, great care should be taken to ensure that valley boards and valley irons form a continuous water path to the eaves and that the lip of the valley should at all points, reach the height of the roofing battens.

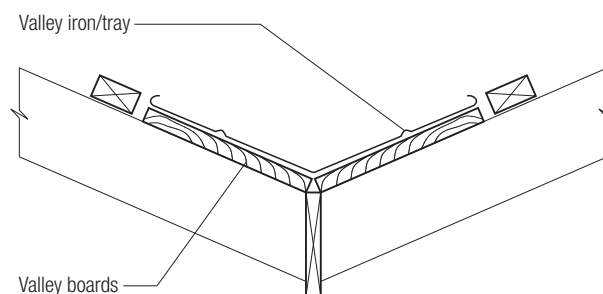
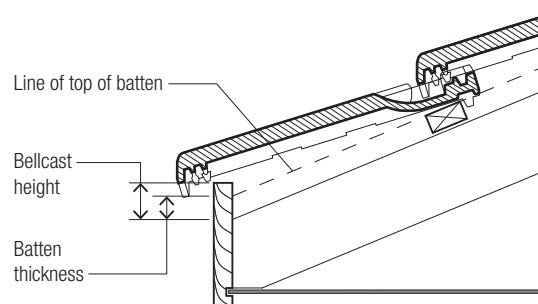

Figure 10: **Standard Valley Detail**

Fascia Height

The “bellcast” or “tilt” is the additional height required on the fascia or bellcast/tilt batten (fascia batten) in order to bring the nose of the gutter course of tiles up to the correct height to enable the first tile course to sit on the same plane as the remainder of the roof.



$$\text{Bellcast height} = \text{Batten thickness} + 25\text{mm}$$

Figure 11: **Fascia Height**

» Installation Details

Barge Height

The barge boards, where fitted, should be aligned to the level of the top of the roof battens.

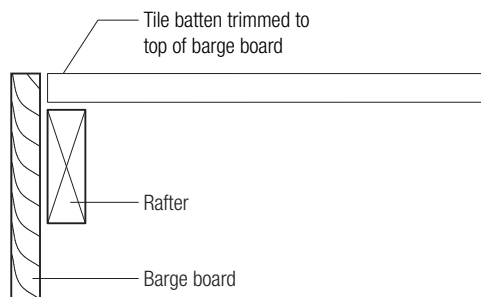

Figure 12: **Barge Height**

Anti-Ponding Boards

Where sarking is used anti-ponding boards should be installed at any point where the sarking might dish to a negative pitch.

Anti-ponding boards are mandatory in the following situations:

- On sarked roofs with pitches less than 20°.
- On all roof pitches where sarking is used and there is no eaves overhang.

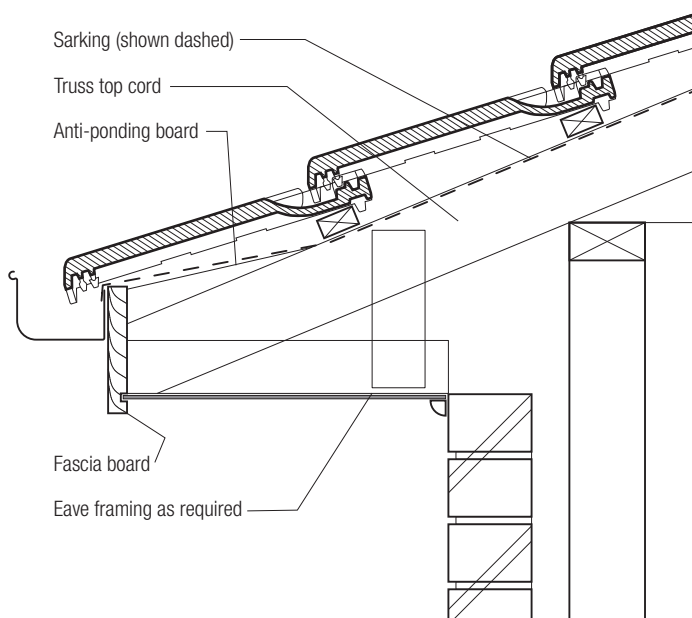

Figure 13: **Anti-Ponding Boards at Eaves**

Laying the Roof

Laying and Securing

Tiles should be laid and secured in accordance with AS 2050 Installation of roof tiles. All courses should be aligned horizontally and vertically. Secure tiles and ancillaries as per tables below.

Table 9: **Minimum Mechanical Installation Requirements for Tiles and Ancillaries - Non-Cyclonic**

Wind Classification	Tile Fixing		Ridge, Hip and Barge Tiles
	Edge of Roof	Field of Roof	
N1 and N2	Mechanically fasten each full tile in second course and then every second tile in every course or every tile in each alternative course		Mechanically fasten each tile
N3	Mechanically fasten each full tile in second course	Mechanically fasten each second full tile in every course	Mechanically fasten each tile
N4	Mechanically fasten every full tile	Mechanically fasten every full tile	Mechanically fasten each tile

Notes:

1 Laboratory testing has shown that only a minor deflection of truly adherent mortar will result in breakage of either ridge tile, or both, upon deflection of the roof. In most instances of mortar bedding and pointing, a truly long-term adherent bond does not exist. Experience has shown that, in practice, roofs deflect and mortar does inevitably break. Therefore, mortar bonding should not be used as a minimum mechanical installation.

2 For pitches over 35°, extra precautions shall be taken. Refer to tile manufacturer for technical recommendations.

Table 10: **Minimum Mechanical Installation Requirements for Tiles and Ancillaries - Cyclonic**

Wind Classification	Tile Fixing		Ridge, Hip and Barge Tiles
	Edge of Roof	Field of Roof	
C1 and C3	Mechanically fasten every full tile	Mechanically fasten each second full tile in every course	Mechanically fasten every tile
C1 and C3	Mechanically fasten every full tile		Mechanically fasten every tile

Notes:

1 Laboratory testing has shown that only a minor deflection of truly adherent mortar will result in a breakage of either ridge or tile, or both, upon deflection of the roof. In most instances of mortar bedding and pointing, a truly long-term adherent bond does not exist. Experience has shown that, in practice, roofs deflect and mortar does inevitably break. Therefore, mortar bonding should not be used as a minimum mechanical installation.

2 For pitches over 35°, extra precautions shall be taken. Refer to tile manufacturer for technical recommendations.

3 For values greater than C3, refer to manufacturer's recommendations.

4 Flexible pointing shall not be used as the sole mechanical fastening material for ridge and hip caps in C2 and C3 wind areas. A suitable clip, screw or similar fastening device must be used.

» Installation Details

First Course

The first course of tiles should be positioned to provide an adequate projection over the fascia and into the gutter.

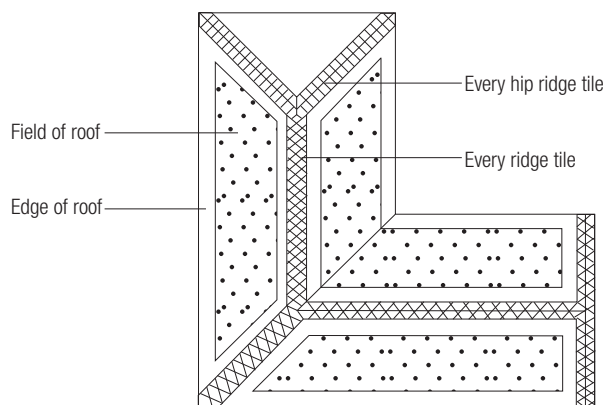

Figure 14: Plan of a Typical L-shaped Hip and Gable Roof

Roof Tile Fixing Systems

The design of the LUTUM roof tile allows various fixing methods to be used. Common practice is to nail fix or clip tiles.

LUTUM recommends that where clip fixing is required, the clips will be fixed at the SIDE LAP.

Extra precautions may be required to combat wind loads or corrosion of the fastenings.

Contact LUTUM for technical recommendations.

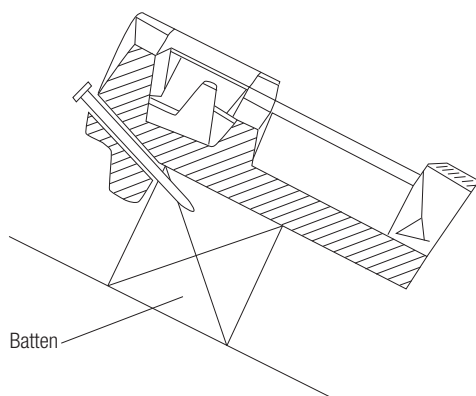

Figure 15: Nail Hole Position French, Swiss and Shingle

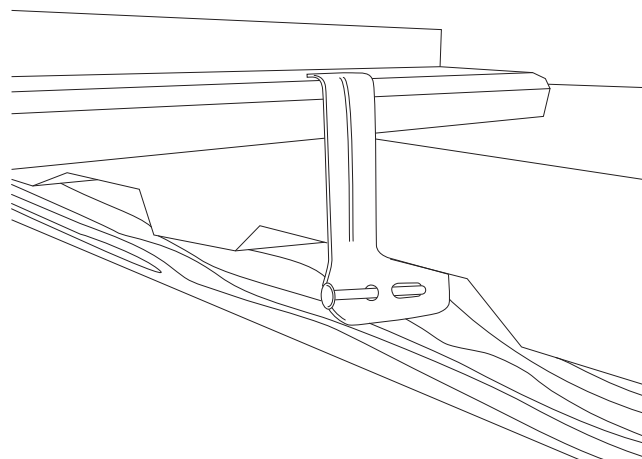

Figure 16: Nail in Side Lap Clip (FCTCNSCFL)
 Suits Vogue, Linea and Striata Tiles

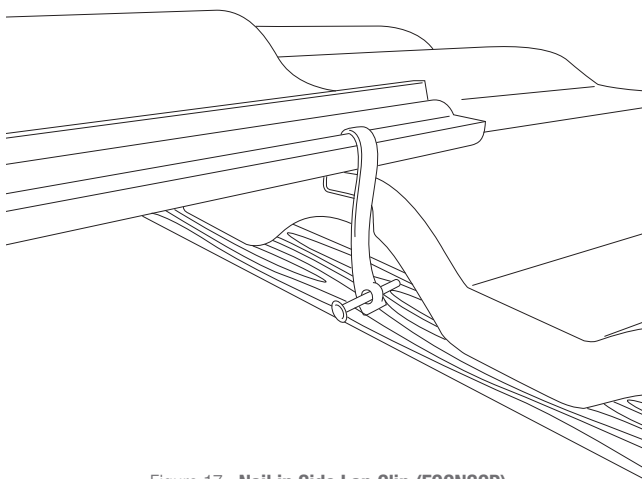

Figure 17: Nail in Side Lap Clip (FCNCSCLP)
 Suits Macquarie, Slimline, French and Shingle Tiles

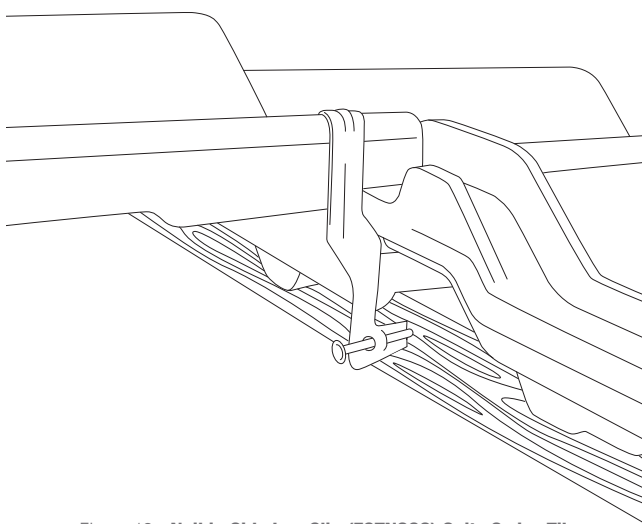

Figure 18: Nail in Side Lap Clip (FCTNSCS) Suits Swiss Tile

» Installation Details

Sarking

Sarking has two primary purposes, the provision of a reflective foil finish minimises heat transmission into the roof space and as a water resistant membrane sarking provides a secondary barrier to water entry, particularly at lower roof pitches and where high wind can cause a drift or spray of moisture to pass into the roof space. Sarking is mandatory where the wind classification is greater than N3.

There are also a number of circumstances, which dictate the use of sarking as a protective measure against damage irrespective of roof pitch.

- Where local regulatory authorities require the use of sarking or where extreme weather conditions are probable ie cliff tops, open exposed site or bushfire prone areas.
- Where overhanging trees leave the possibility of the occasional branch breaking, resulting in broken tiles.
- Immediately underneath and extending to the gutter around solar hot water collectors.
- Where water run off from a high level valley discharges onto tiled roofs, sarking can be used to conduct any penetrated water away. When sarking is used in this manner it shall be a minimum width of 1800mm either side from the point of discharge and extend down to the eaves gutter.
- Where sarking is used as a condensation barrier.
- At any change of roof pitch and extending from there to the eaves gutter.
- Where radiant heat is a problem.
- Where rafter length exceeds 4.5 metres (see table 3).
- Where the roof pitch exceeds 45°.
- To avoid constant flexing and increase the life of the sarking, anti-flap pads are recommended.

The typical roofing details indicating the acceptable methods of use for sarking:

Where roof pitch exceeds 45° the whole roof shall be sarked, (not required in Victoria). Where a valley discharges water onto a lower roof, such roof may require sarking from lower end of the valley to the fascia, with a minimum of 1.8 metre width from the side of the valley. Notwithstanding the above provisions, where local site conditions are believed to involve greater than average normal exposure to wind driven rains, it may be necessary to increase roof pitch and/or tile lap and/or fixing requirements and/or sarking, which may exceed the normal tabulated requirements.

Locations, which may require special consideration include all coastal areas, installations on high ground and high rise buildings where design criteria for wind classification is greater than N2.

Table 11: **Duty Classification and Allowable Use in Australia**

Use	Extra Heavy	Heavy	Medium
600mm spans	Allowable	Allowable	Allowable Must be supported below if the wind classification exceeds N3.
>600mm 900mm spans	Allowable	Allowable, if supported below.	Allowable, if supported below.
>900mm spans	Allowable, if supported below.	Allowable, if supported below.	Allowable, if supported below.

Sarking is mandatory when the wind classification is greater than N3.

Eaves

Sarking material should be carried over fascia board a minimum of 25mm to give drip into gutter. At this point, material should be supported to prevent ponding. An approved anti-ponding board is mandatory at pitches less than 20° or where roof are sarked with no eaves overhang regardless of pitch.

Valleys

At valley gutters the sarking membrane should finish at the valley iron and be fixed by a valley batten, if carried into valley iron then material should project a maximum of 20mm. If sarking projects too far into valley, the roof will almost certainly leak.

Laps and Joins

The sarking membrane should be lapped 150mm at horizontal joints and across both rafters at vertical joints.

» Installation Details

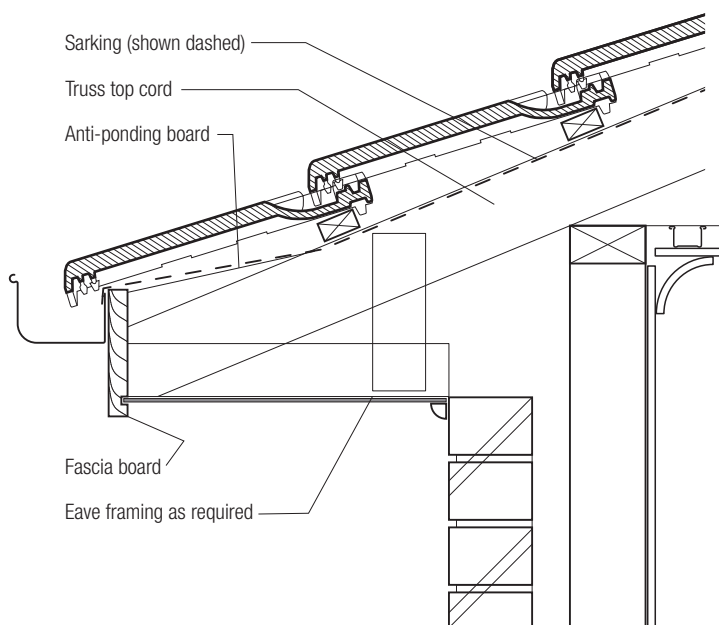

Figure 19: **Standard Sarking Detail**

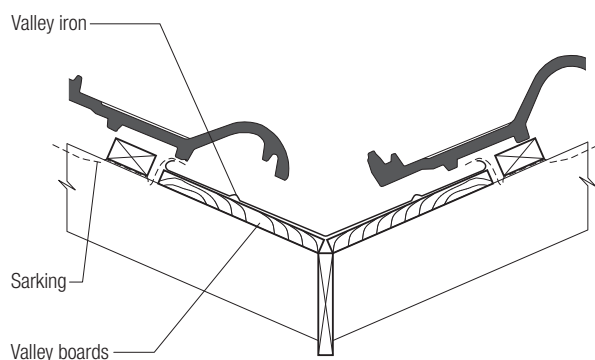

Figure 20: **Valley Sarking Detail**

Ridge Systems

LUTUM manufacture and supply various types of ridge capping. Concrete and terracotta vee ridge is available as standard (130°) or steep angle (81°) inclined angle.

All LUTUM ridge caps may be positively fixed (mechanically fastened) if required.

Ridge Installation

(General) after the roof tiles have been laid and the hip tiles cut in, install the ridge capping. Requirements of Australian Standard 2050 Installation of roof tiles provides the following information:

- All ridge, hip and barge tiles are to be mechanically fastened.
- The cutting of tiles at ridges and hips shall extend under the capping by a sufficient distance to be weatherproof.
- All cut tiles will be supported to ensure they are in the same plane as adjacent tiling.
- All capping will be laid/set to achieve a straight and regular line of ridge capping.

LUTUM roof tile specifications:

- All junctions of hips and ridges should be made weatherproof, either by a purpose made fitting or by close joining with an under soaker or over flashing. Three way, four way and spoon apexes are available for joining hip and ridge sections.
- Lapping of ridge tiles should be directed away from the prevailing winds.
- The front tip of the hip starter is to be set 50mm into the gutter in line with the eaves course of tiles.
- Cut tiles at hips should be supported by galvanised nails spiked to the hip boards where necessary.
- Weep holes are to be pushed through the mortar bed at top ridges on all concrete tiles or cut terracotta tiles. Weep holes to be placed one per tile pan.
- Cut tiles at hips are to be aligned with adjacent tiling.

» Installation Details

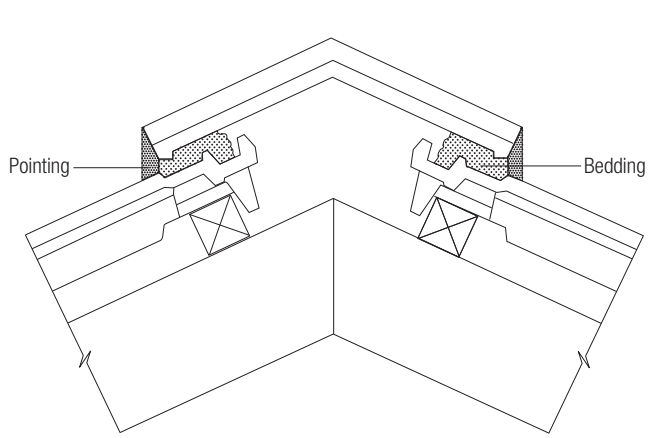

Figure 21: **Vee Ridge (130°) Typical Detail**
(Concrete and Designer/Ceramic Terracotta)

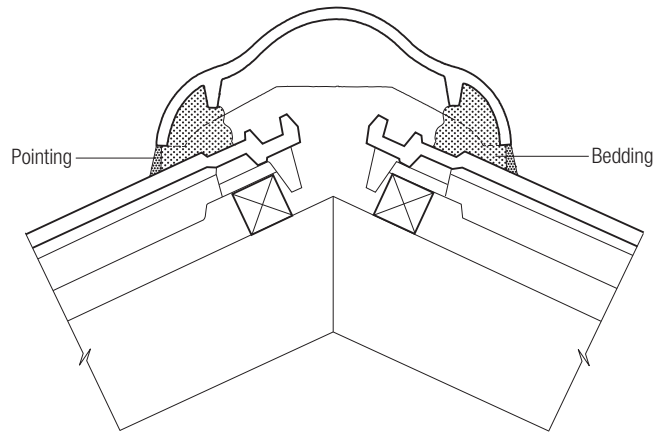

Figure 22: **Arched Ridge Typical Detail** (Terracotta only)

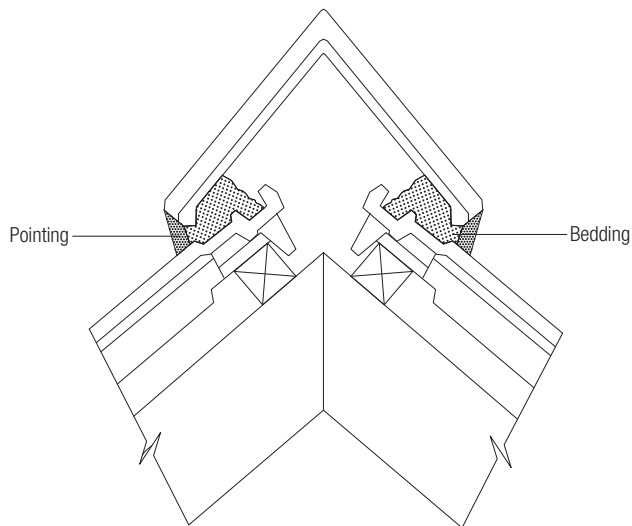

Figure 23: **Vee Ridge (81°) Typical Detail**
(Concrete and Terracotta Designer/Ceramic)

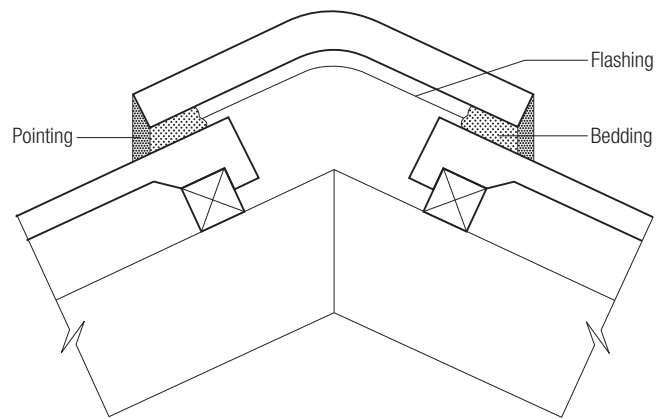

Figure 24: **Butt Ridge System** (Cross Section) (Concrete)

» Installation Details

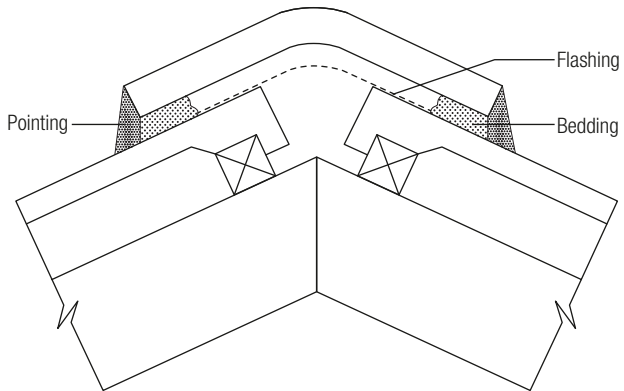

Figure 25: **Streamline Ridge Typical Detail** (Concrete)

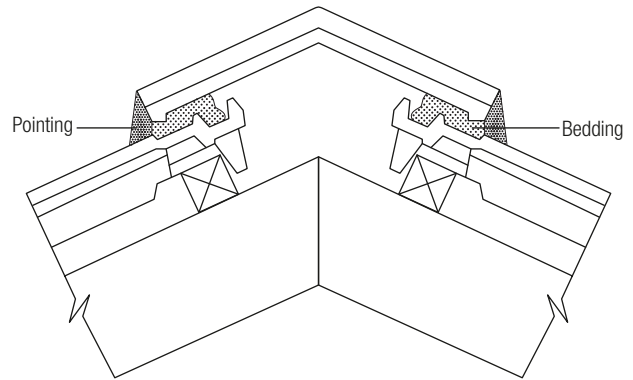

Figure 26: **Accent Ridge Typical Detail** (Designer Ceramic)

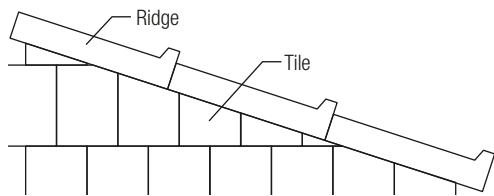

Figure 27: **Classic Ridge Design Elevation** (Terracotta)

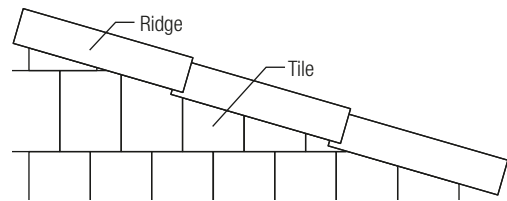

Figure 28: **Classic Ridge Design Elevation** (Concrete)

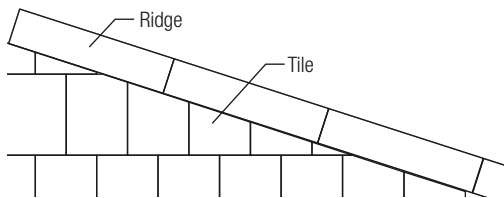

Figure 29: **Classic Ridge Design Elevation** (Concrete/Designer Ceramic)

» Installation Details

Hip Details

The following are suggested details suitable for hips. These details are by no means exhaustive. Recommendations of experienced tilers may offer a further source of details. Shape starter tile to foot of all hips. Cut LUTUM roof tiles closely to the rake of the hip to leave a maximum gap of 20mm between hip cuts. Fix apex tiles to all junctions of hips and ridges.

Starter tiles on hips must project into gutter in line with the eaves course tiles.

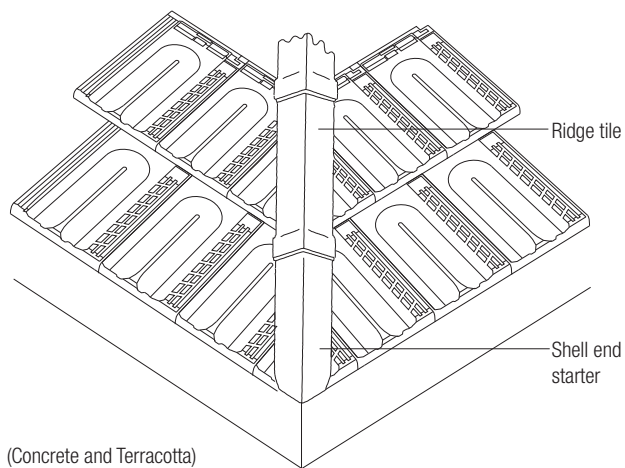

Figure 30: **Standard Hip Detail**

Valley Boards

Valley boards should be a minimum of 19mm thick, be below the top of the tile batten and extend the full width of the valley.

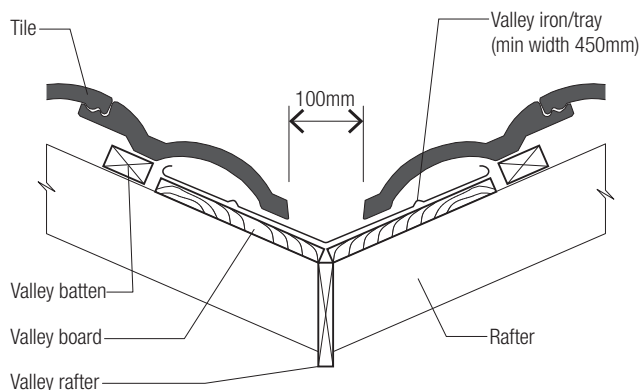

Figure 31: **Valley Junction Detail**

Sarking at Valleys

Where sarking is used, it should overlap the valley by no more than 20mm and be held in place by a valley batten fixed parallel to the valley board.

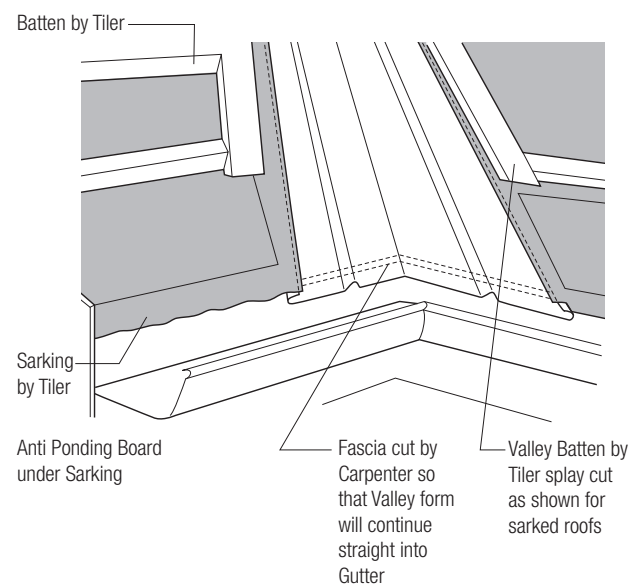

Figure 32: **Sarking at Valleys**

» Installation Details

Valley General

Under normal conditions a gap of 100mm between tiles is acceptable.

In high rainfall areas the valley tiles can be bedded and pointed or sealed with a sealant strip and the gap between the cut tiles may be increased up to 180mm.

Valley irons/trays should be treated with corrosion inhibiting materials prior to bedding and pointing.

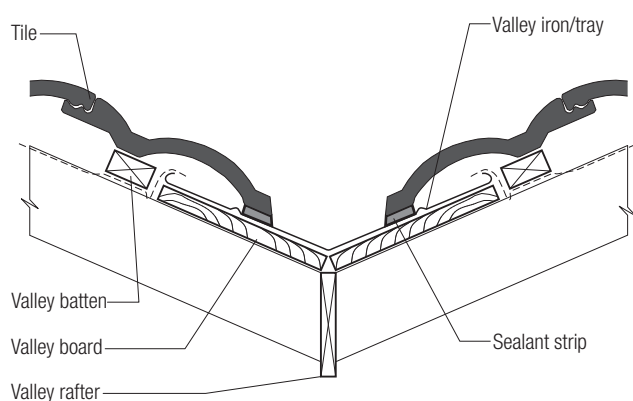

Figure 33: Valley for High Rainfall Areas

Barge/Gable Systems

There are a number of ways of setting a barge/gable end. These include; a) bed and point, b) barge tiles and c) secret gutter, and can be applied according to local requirements and exposure conditions.

Good tiling practice in States and Territories have developed various methods of installation of these systems. The information provided in the following text may not be common practice in your State or Territory. Please contact your state LUTUM Sales Office for technical details.

Bed and Point

- Place bedding strip of 5mm fibre cement 100mm wide over the metal Z flashing, which sits on top of the barge board and bed roof tile to it. The projection over the barge board shall be a minimum of 10mm and a maximum of 25mm. Point neatly without visible trowel marks.
- With a bed and point finish the projections at gable ends should be left to the tilers discretion, thus ensuring the finishing off with a full tile at all left hand gables whenever practicable. The exposed side water channel to all left hand gables should be removed. Where the overhang is of sufficient width it is advisable for the carpenter to fix a quad moulding under the fibrous cement undercloak prior to bedding and pointing.
- All verge tiles shall be mechanically fixed.
- The barge board must be kept flush with the top of the batten. This is to allow the fibro strip to be let into the batten to sit level with the top of the batten and barge board.

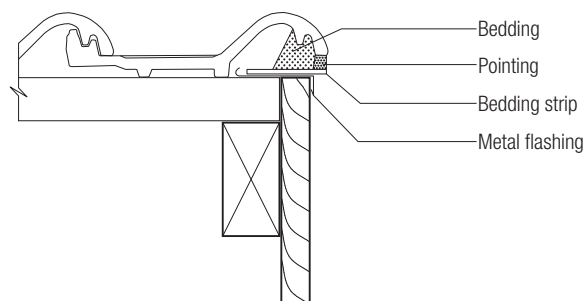

Figure 34: Bed and Point Barge Detail

» Installation Details

Barge Roll/Cap

Universal barge roll/caps are laid over the gable end and screw fixed to the barge boards. The top of the barge board should be flush with the top of the tiling batten. The barge roll/caps are to be screw fixed according to local specifications. In some cases LUTUM Concrete Barge Roll/Caps may be fixed without bedding and pointing.

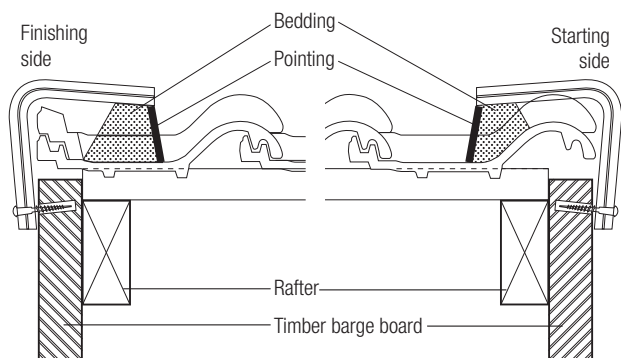

Figure 35: **Bed and Point Barge Detail**

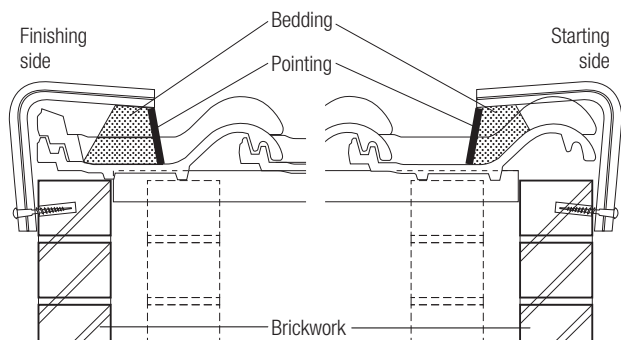

Figure 36: **Tapered Barge Roll/Cap Detail (Fixed to brickwork)**

Secret Gutter Finish

The top of the barge must be 75mm above the top of the battens.

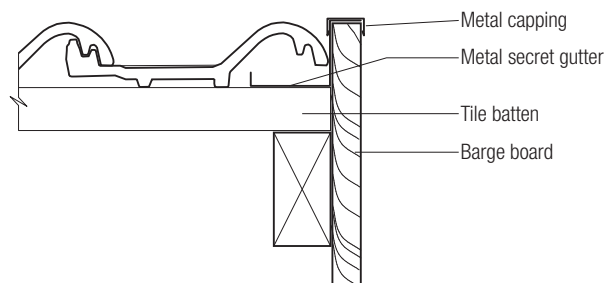

Figure 37: **Barge/Gable Details**

» Installation Details

Roof and Flashing Details

Roof details should take into consideration special flashings required at parapet walls, chimneys and other details. As a general rule flashings should overlap the upstand of at least one tile or provide alternative water run-off details such as secret or soaker gutters. Generally lead flashings are used and these should be at least 20kg per sq m. Where roofs are sarked, consideration should be taken of the ponding of water in the sarking, particularly at eaves and around large penetrations such as chimneys and skylights etc. Anti-ponding boards should be installed at these points either by the builder, carpenter or tiler. The following are typical details of roof flashings, which have proved successful over time. However good trade practice and the expertise of most tilers in unusual details should be taken into consideration.

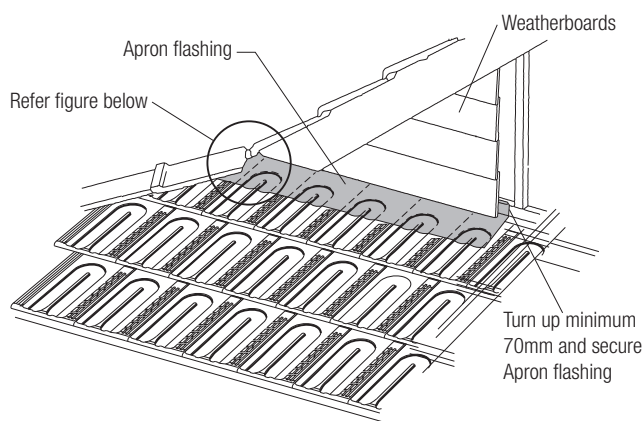

Figure 40: Dutch Gable Flashing

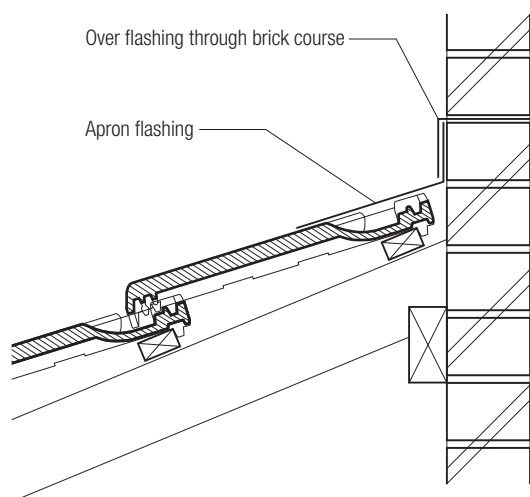

Figure 38: Head Wall Flashings

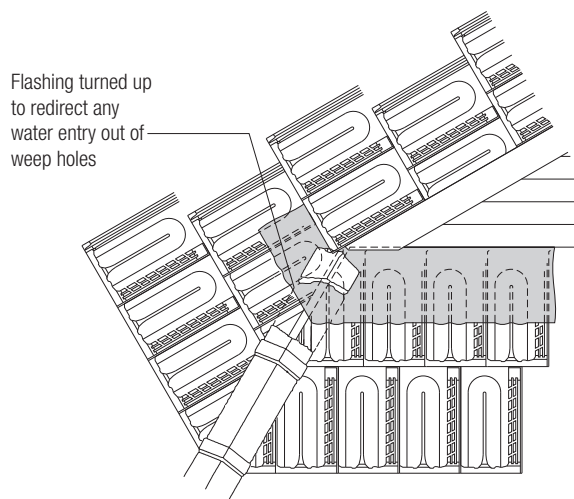

Figure 41: Dutch Gable at Hip and Barge Junction

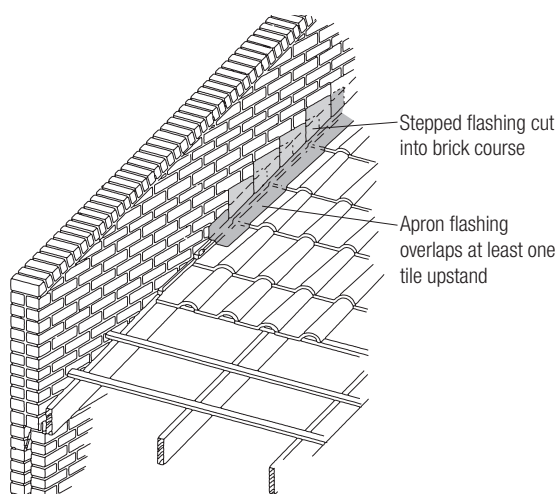

Figure 39: Step Flashing Chased to Brick Course

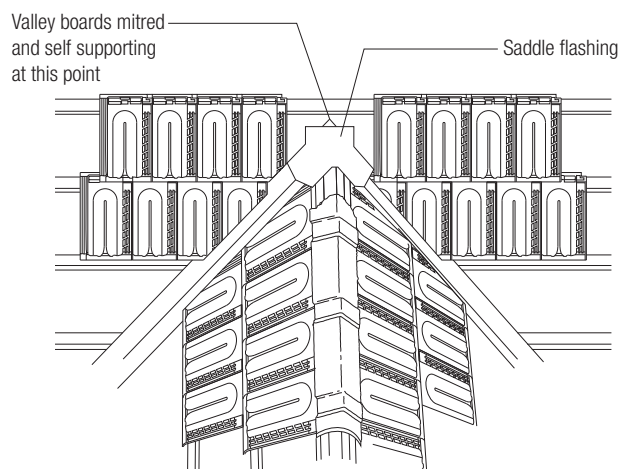

Figure 42: Saddle Flashings

» Installation Details

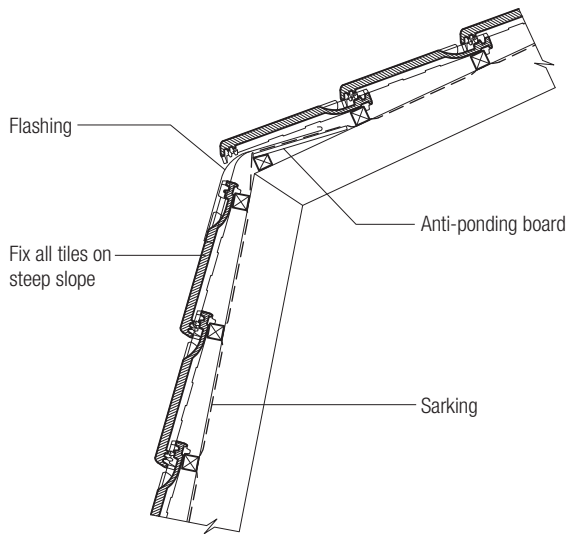

Figure 43: **Mansard Roof**

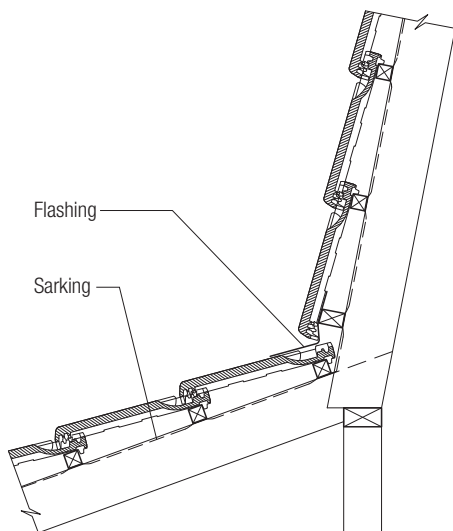

Figure 44: **Change of Pitch**

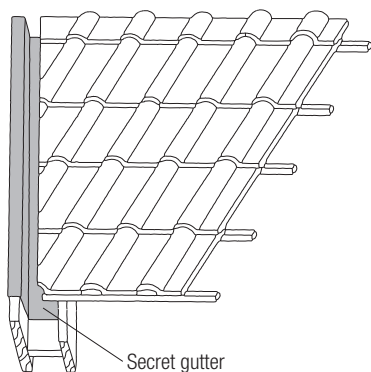

Figure 45: **Splayed Gable**

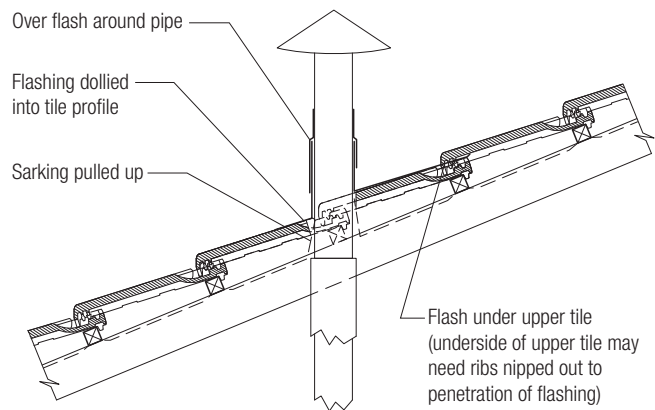

Figure 46: **Pipe Penetration**

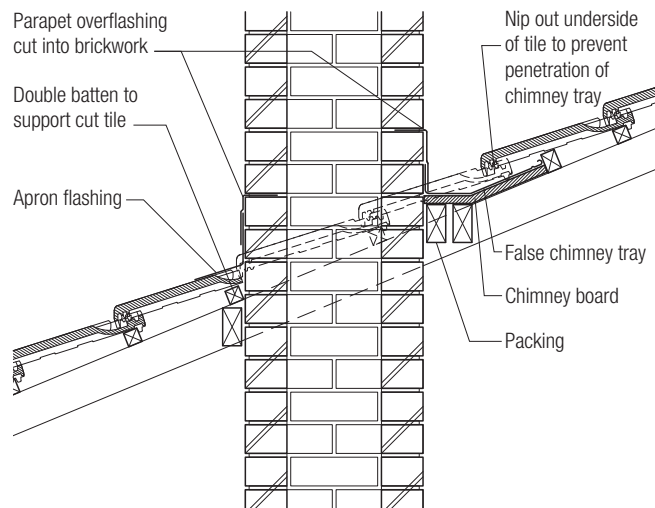

Figure 47: **Chimney Penetration**

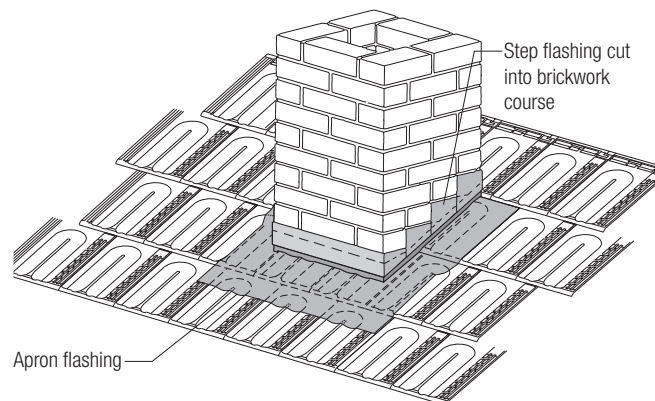

Figure 48: **Chimney Apron Flashing**

» Installation Details

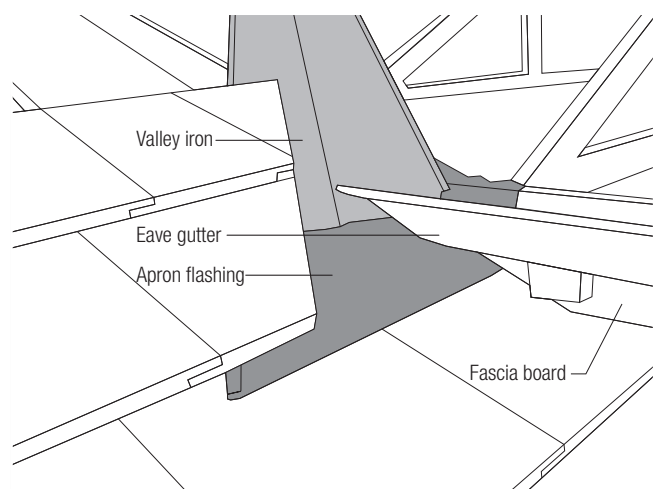

Figure 49: Valley Apron Flashing

Bedding and Pointing

Bedding Mortar Mix

Australian Standard 2050 Installation of roof tiles requires a minimum, "Cement mortar for bedding (1:4) 1 cement, 4 ± 0.4 sand."

The use of other additives such as "Lime or Fire clay" is permitted at the following ratios:

- Fire clay when used, replaces an equal amount of sand therefore, if 1/2 a measure of fire clay is used the ratio would be (1: 0.5: 3.5)...
1 cement, 0.5 ± 0.005 fire clay, $3.5 \pm 0.3.5$ sand.
Fire clay is not a replacement for cement.

The use of plasticizer's and products that aerate mortar is not permitted as these products weaken the mortar.

Pointing Mortar

Cement mortar bonding shall not be used as the mechanical fixing method. It can be used however in conjunction with some other form of mechanical fixing.

- Pointing mortar when used shall be 3-1 mix, 3 clean sharp sand, 1 cement, with oxides or pigments to suit.
- Flexible, premixed pointing is available and in most cases is rated as a mechanical fixing. Check with the manufacturer for confirmation of status.

Bedding and Pointing

The pointing should be neatly trowelled, with an even finish throughout. Collar/cuffs should be pointed (if flexible pointing is the mechanical fixing then it is mandatory to point collars/cuffs).

Roof Completion

Tilers should take care to remove all debris from the roof and gutters on completion of the job and in particular, care should be taken to remove any steel debris – nails etc, which might cause staining of tiles or premature corrosion of gutters should they remain on the roof.

A final detail check should be made on the roof before completion to ensure that any broken or cracked tiles are replaced and the roof is fully weatherproof.

LUTUM Roof Tiles Technical Information Guide

Architectural Details



Architectural Details

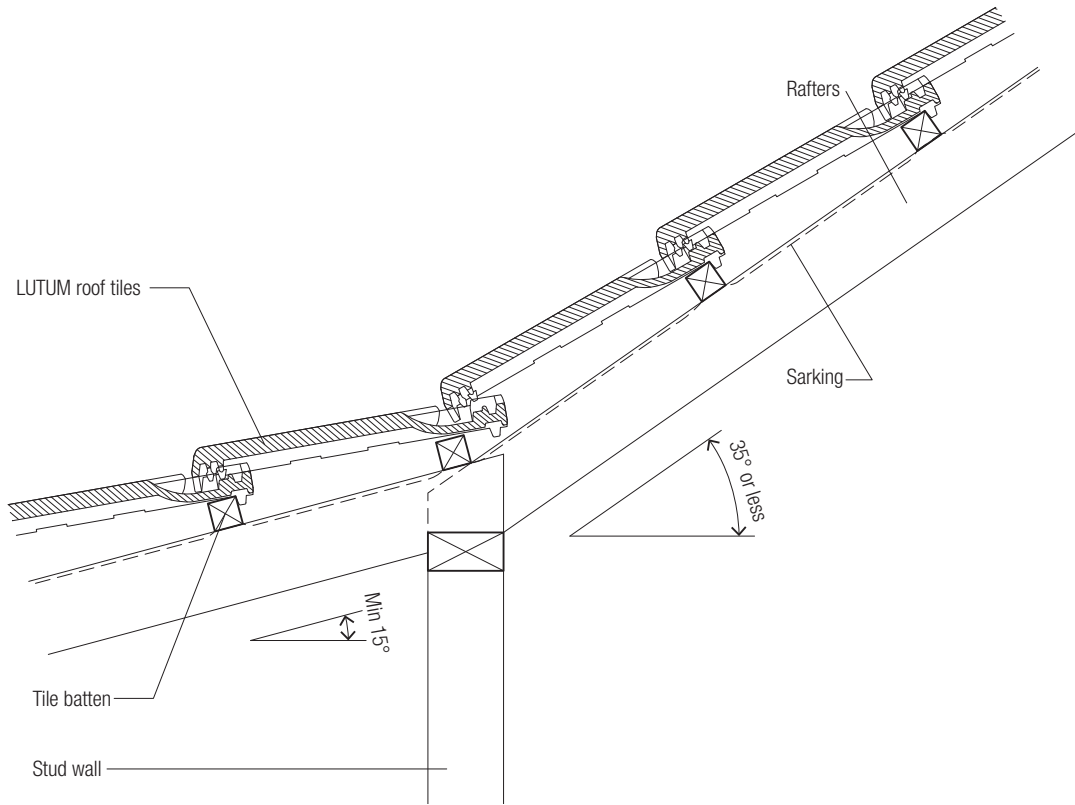

Figure 50: **Change in Pitch** (CAD File BR001 - Available on request)

Note: minimum pitch 15°

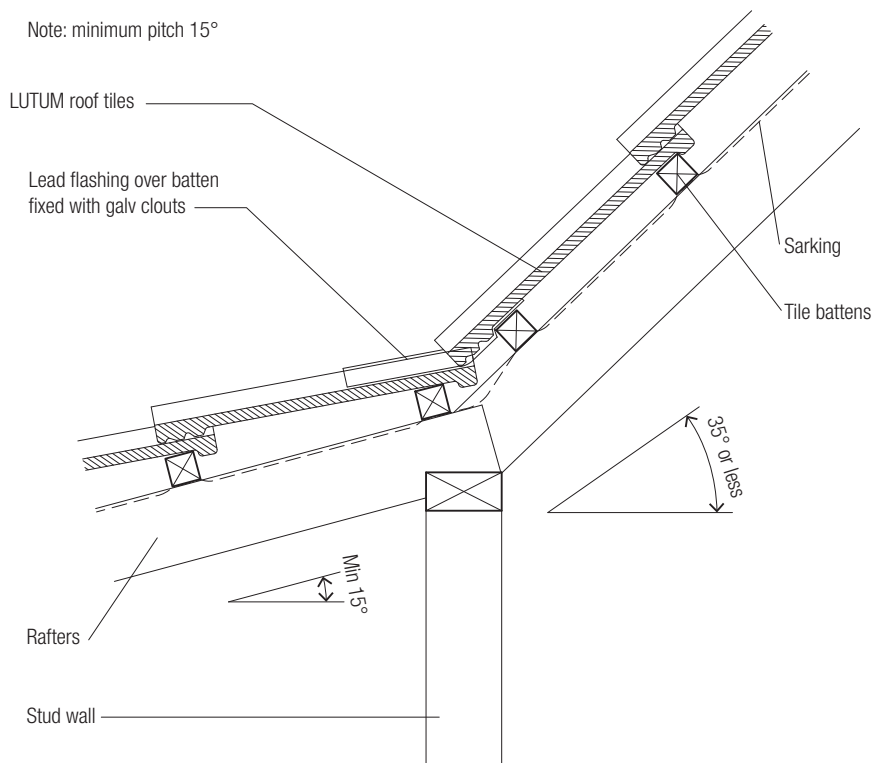

Figure 51: **Change in Pitch - Flashing** (CAD File BR002 - Available on request)

» Architectural Details

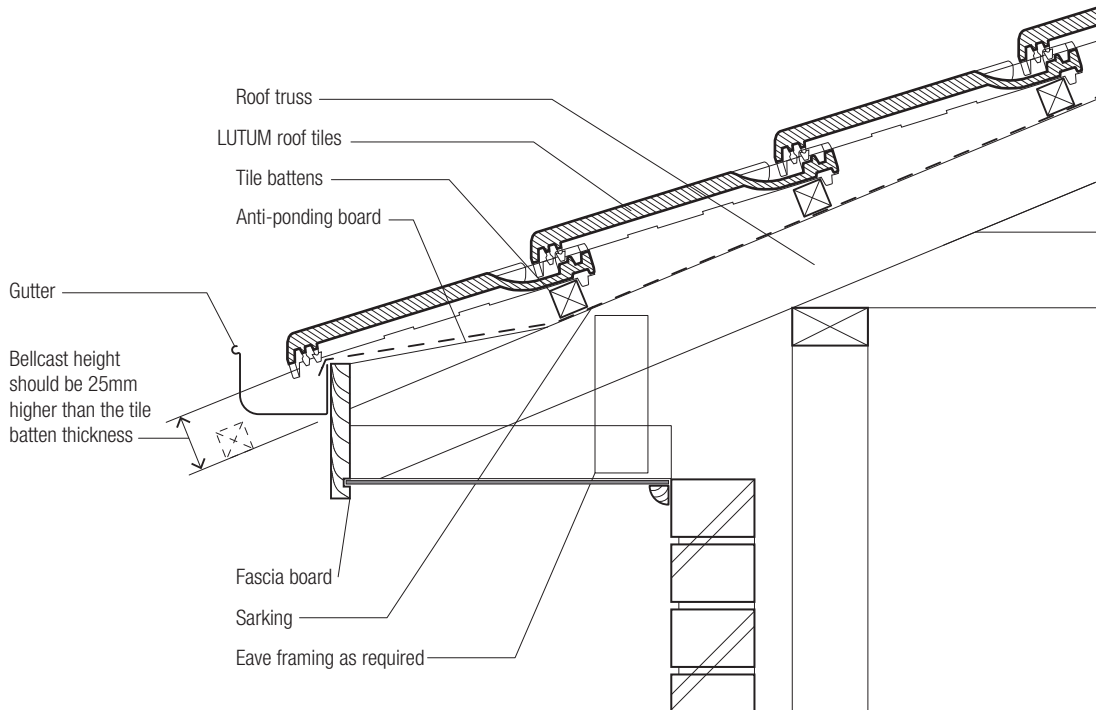

Figure 52: **Eave Detail/Fascia Board/Bellcast Height** (CAD File BR003 - Available on request)

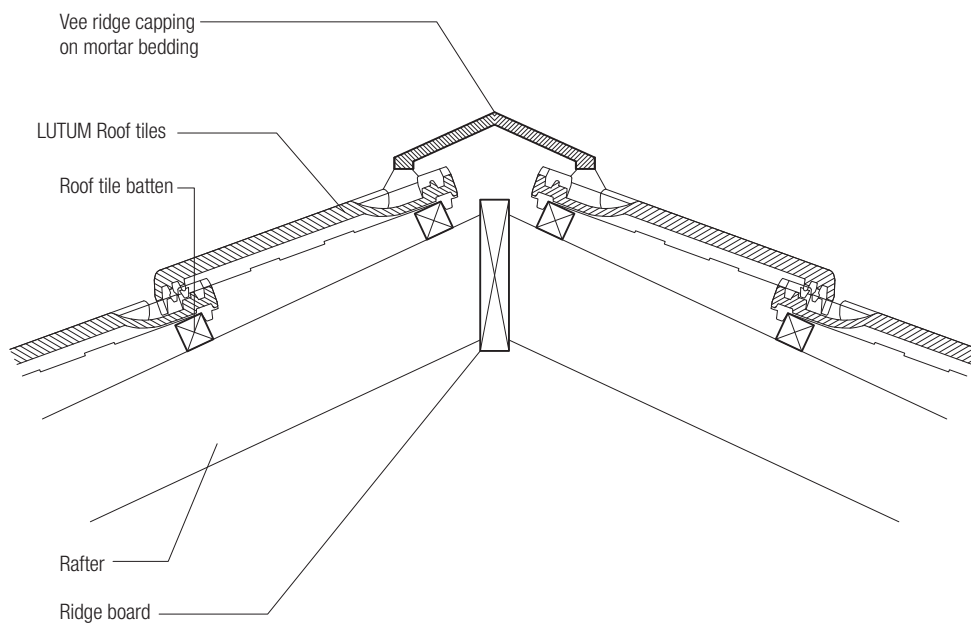

Figure 53: **Ridge Detail** (CAD File BR005 - Available on request)

» Architectural Details

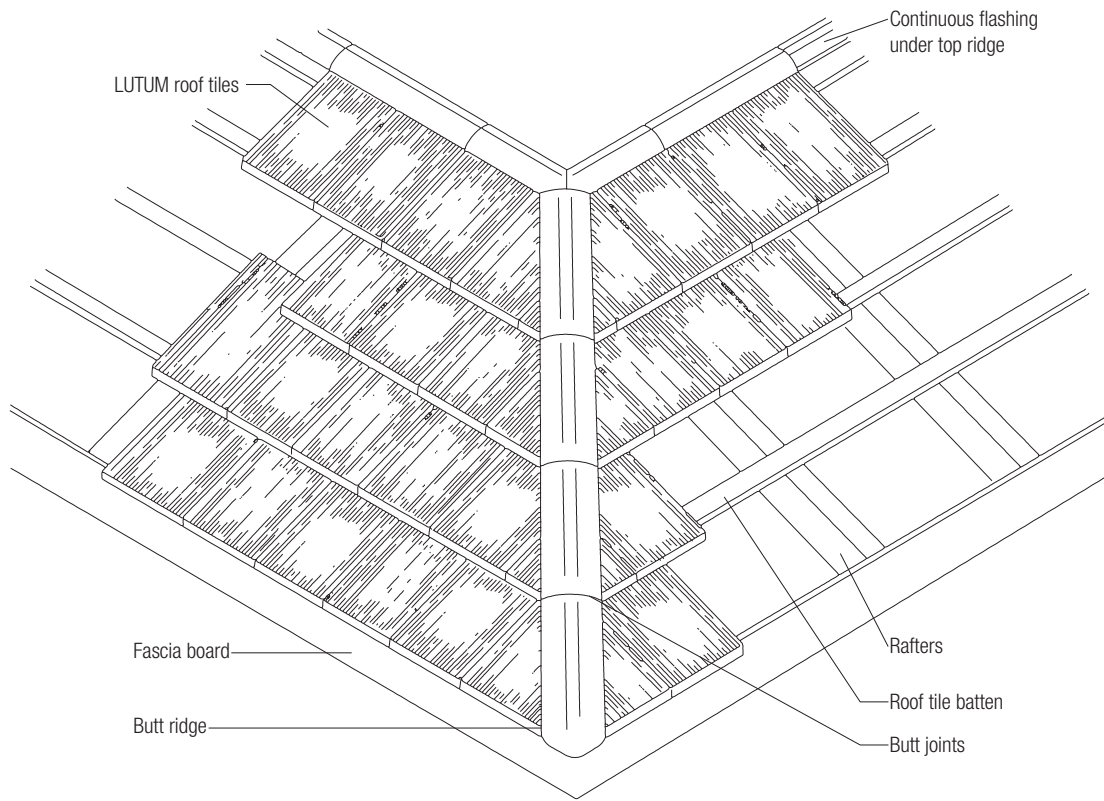

Figure 54: **Butt Ridge System**

» Architectural Details

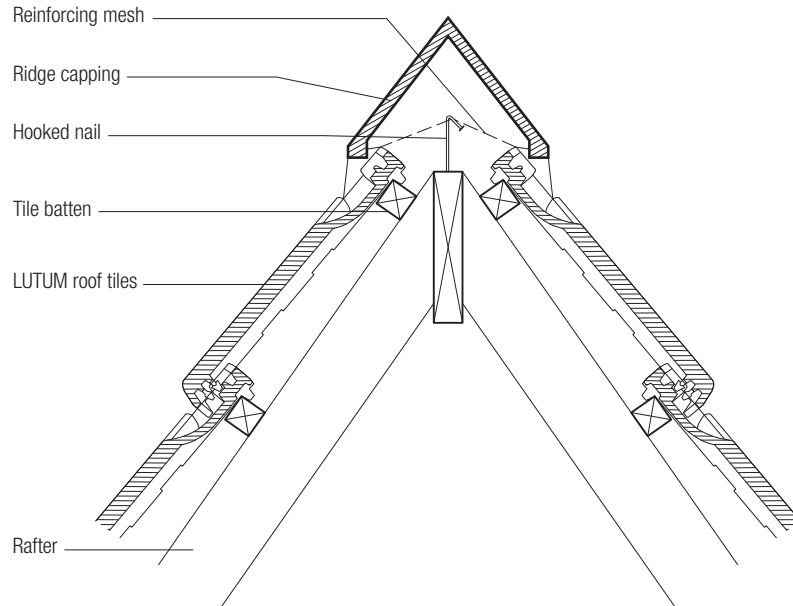

Figure 55: **Steep Pitched Ridge Cap** (CAD File BR006 - Available Available on request)

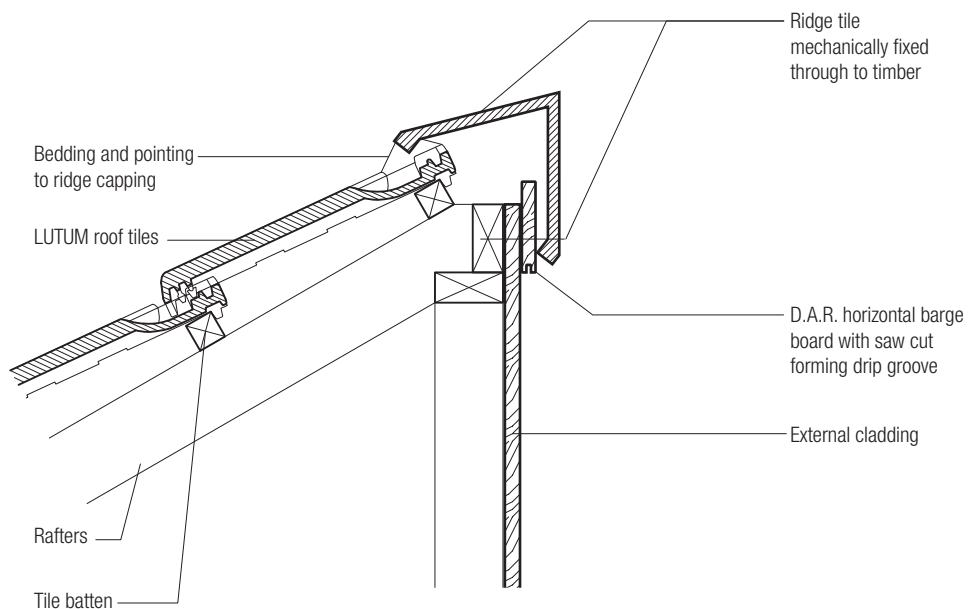

Figure 56: **Saw Tooth Ridge - Steep Pitch Vee Ridge** (CAD File BR007 - Available on request)

» Architectural Details

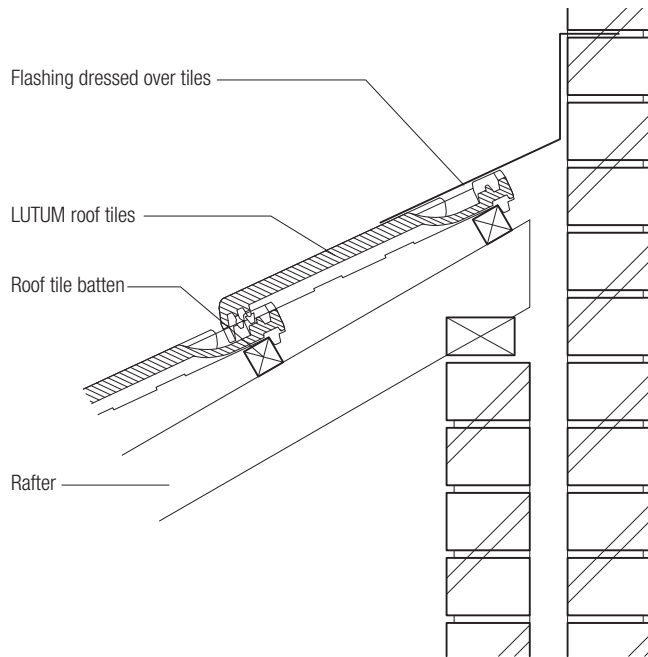

Figure 57: **Flashing to Brick Abutment** (CAD File BR008 - Available on request)

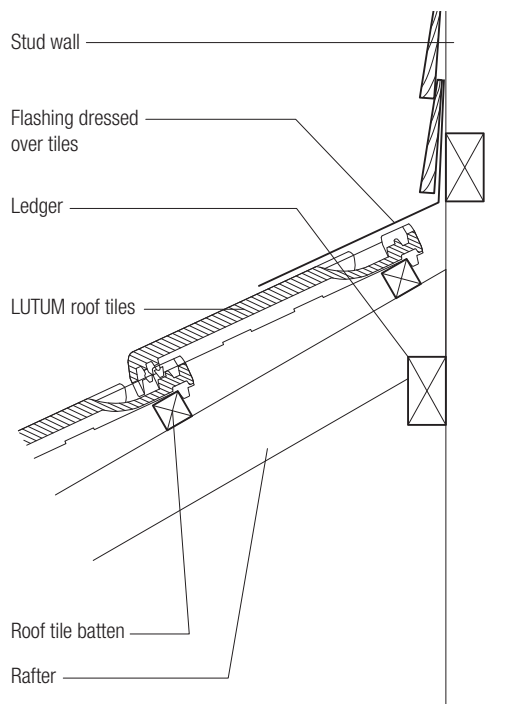

Figure 58: **Flashing to Timber Abutment** (CAD File BR009 - Available on request)

» Architectural Details

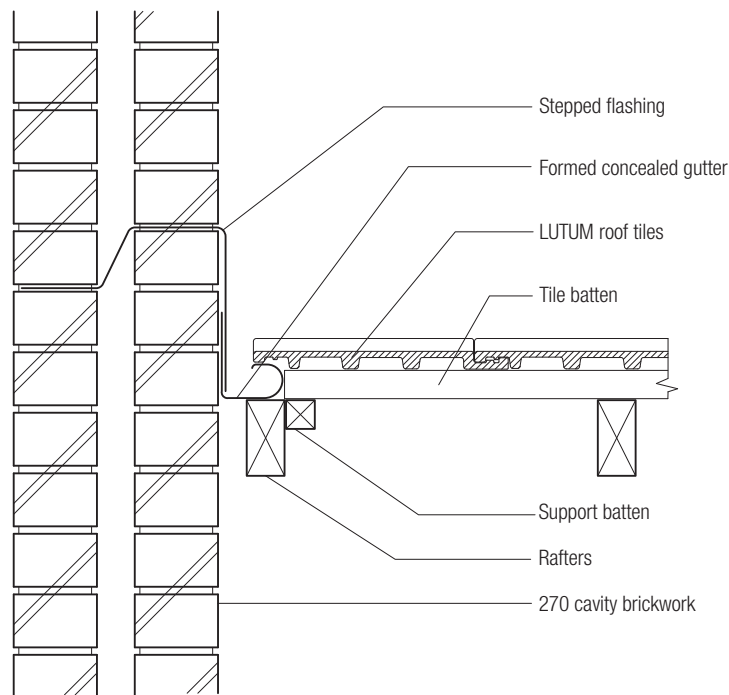

Figure 59: **Parapet Concealed Gutter** (CAD File BR010 - Available on request)

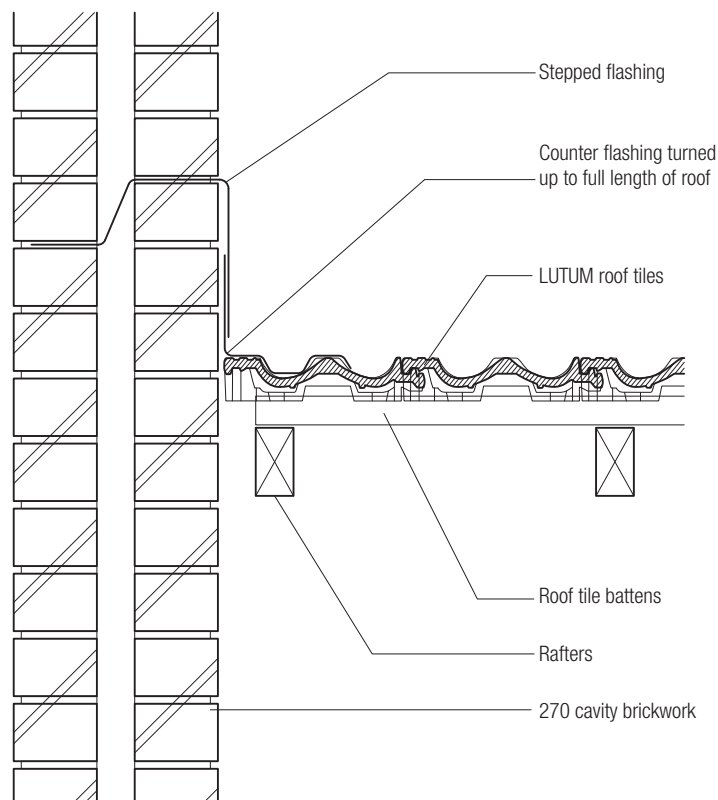

Figure 60: **Parapet - Detail Brick Wall** (CAD File BR011 - Available on request)

» Architectural Details

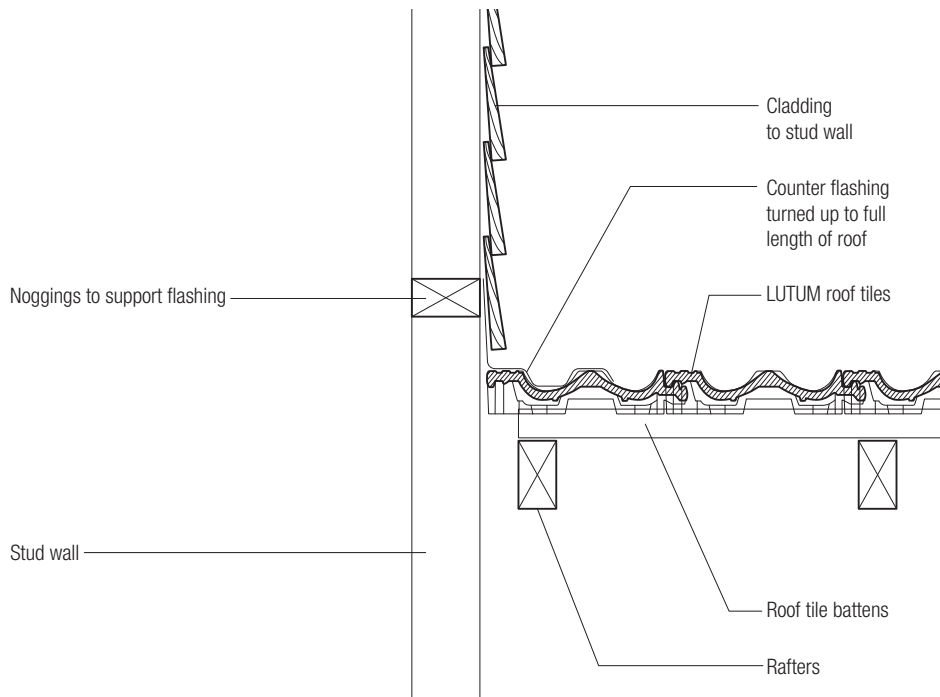

Figure 61: **Flashing to Side Abutment** (CAD File BR012 - Available on request)

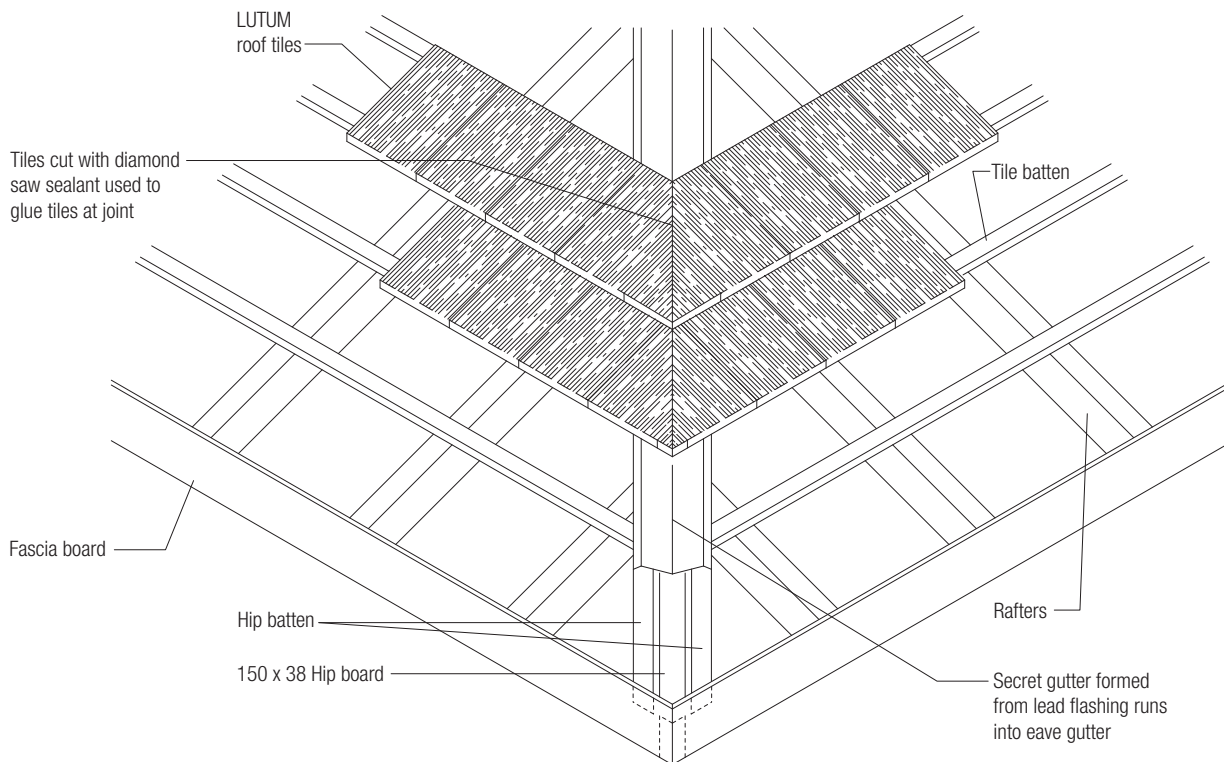

Figure 62: **Mitred Hip** (CAD File BR013 - Available on request)

» Architectural Details

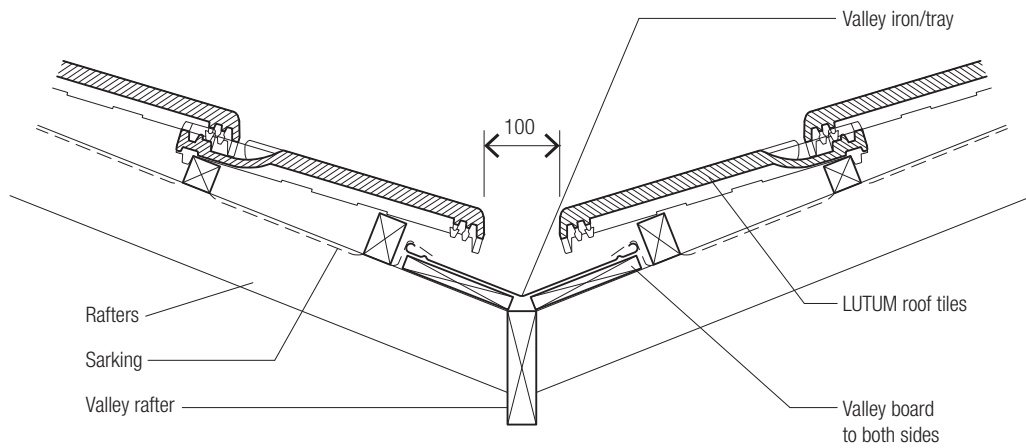

Figure 63: **Valley Detail** (CAD File BR014 - Available on request)

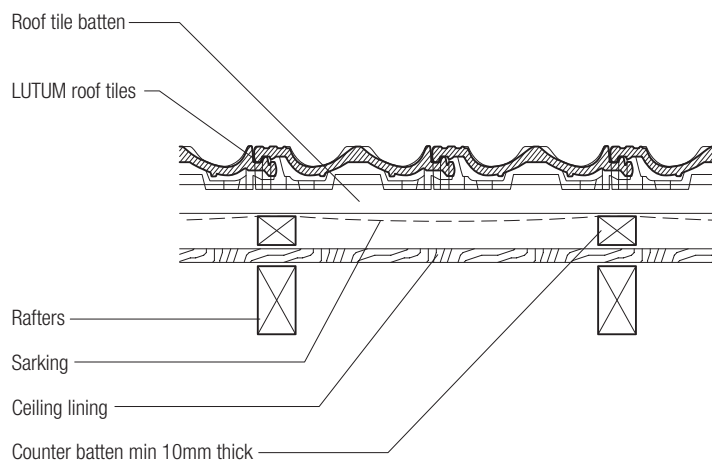

Figure 64: **Counter Batten** (CAD File BR015 - Available on request)

» Architectural Details

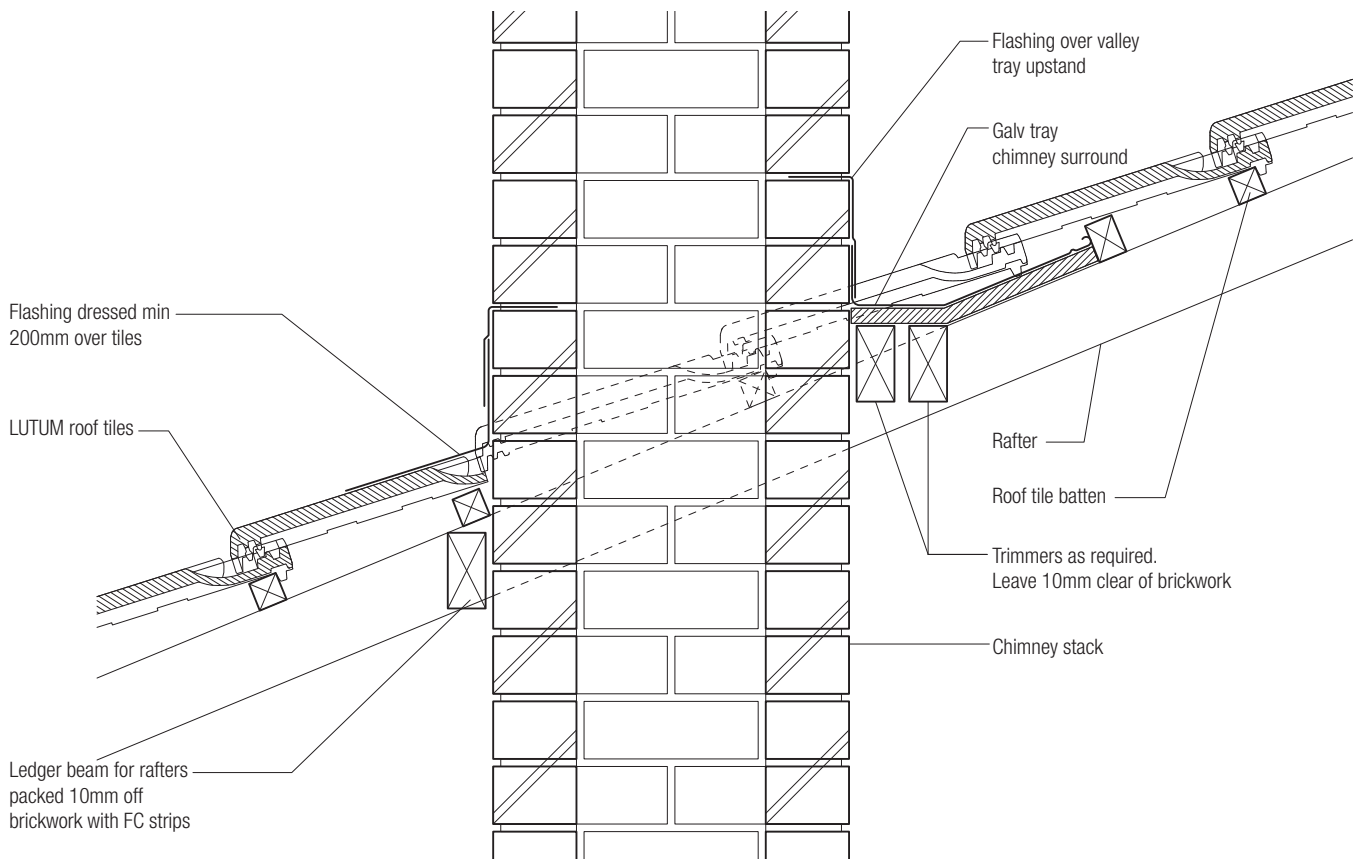

Figure 65: **Chimney Junctions** (CAD File BR016 - Available on request)

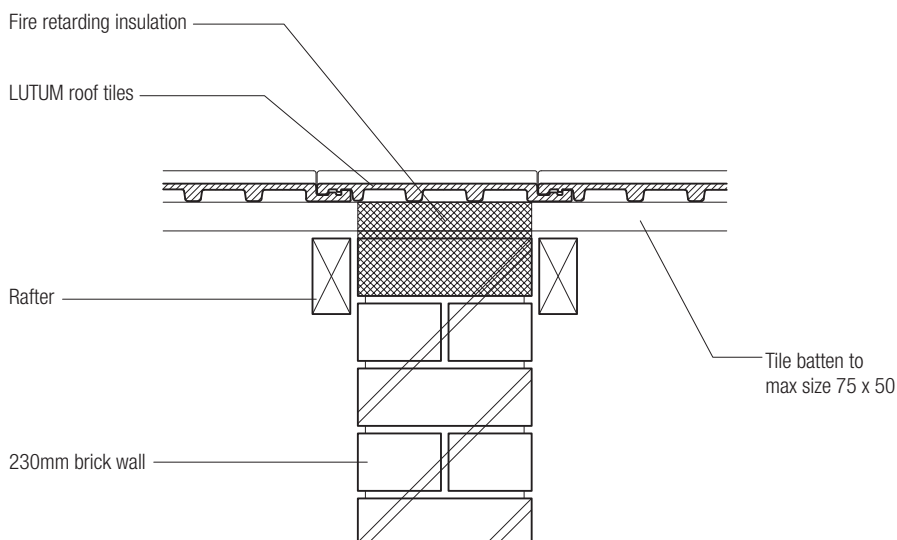

Figure 66: **Tile Over Internal Fire Wall** (CAD File BR017 - Available on request)

» Architectural Details

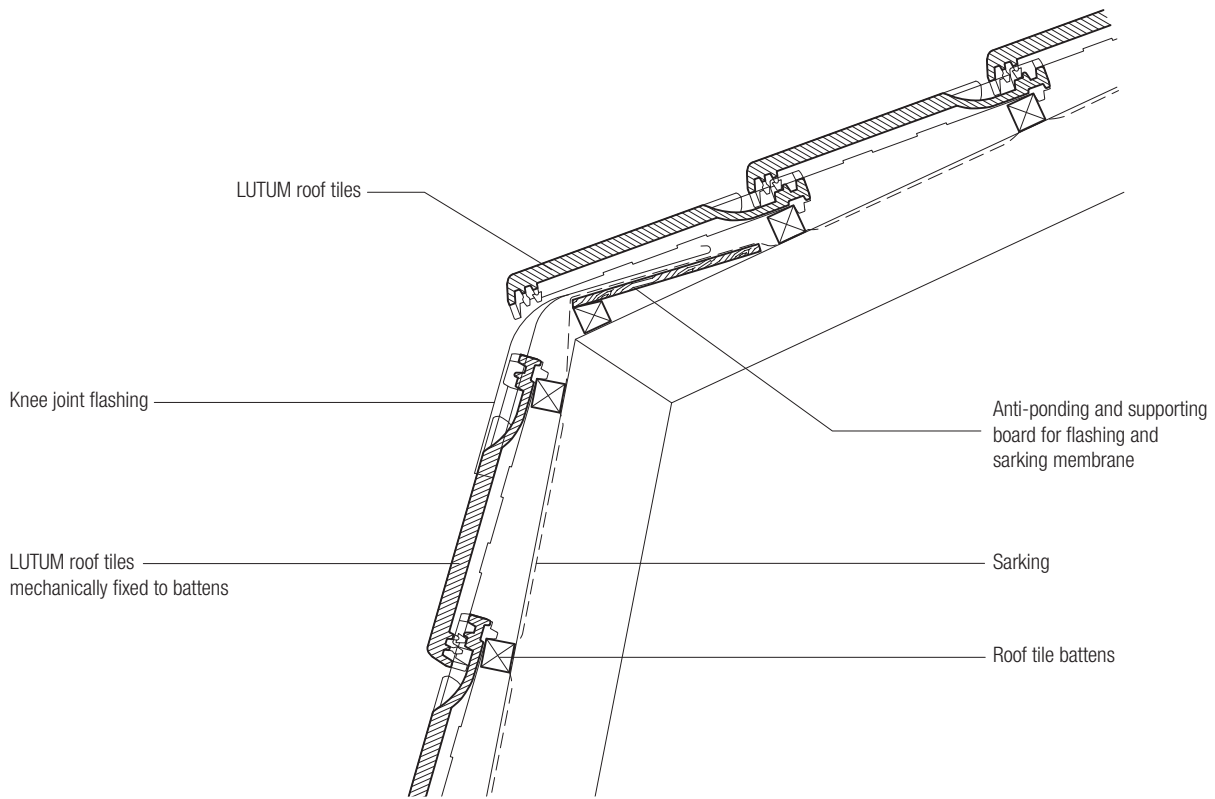

Figure 67: **Mansard Roof** (CAD File BR018 - Available on request)

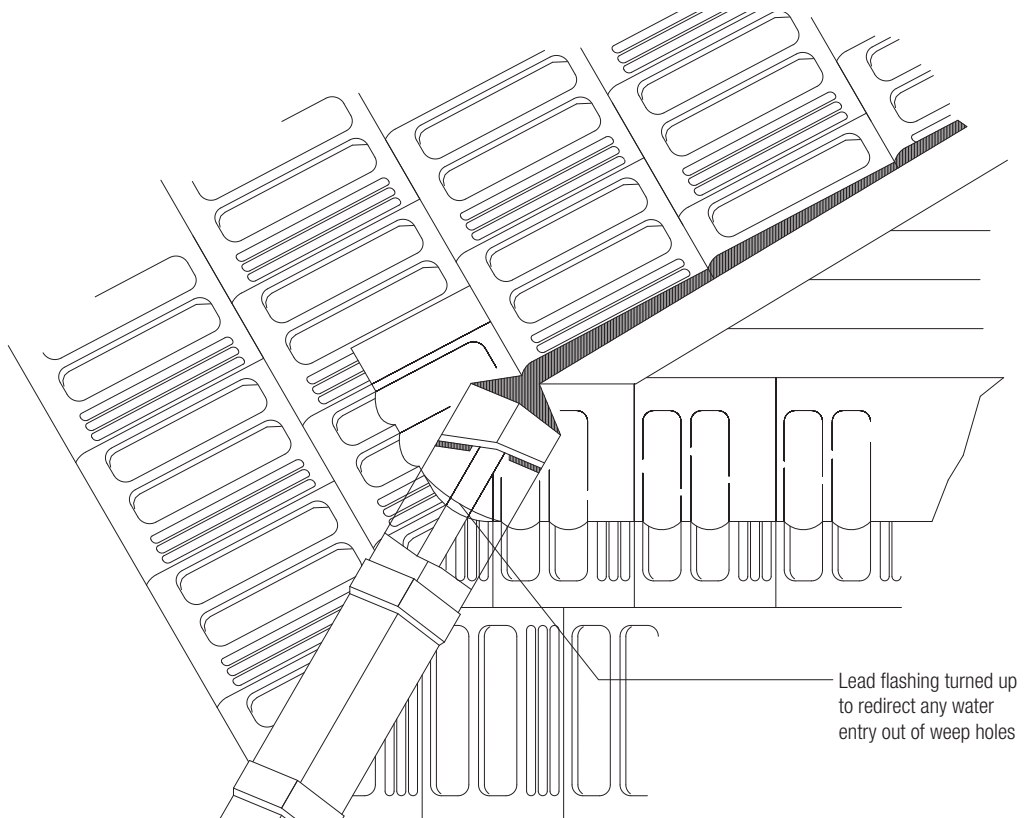

Figure 68: **Elevation of Dutch Gable** (CAD File BR019 - Available on request)

» Architectural Details

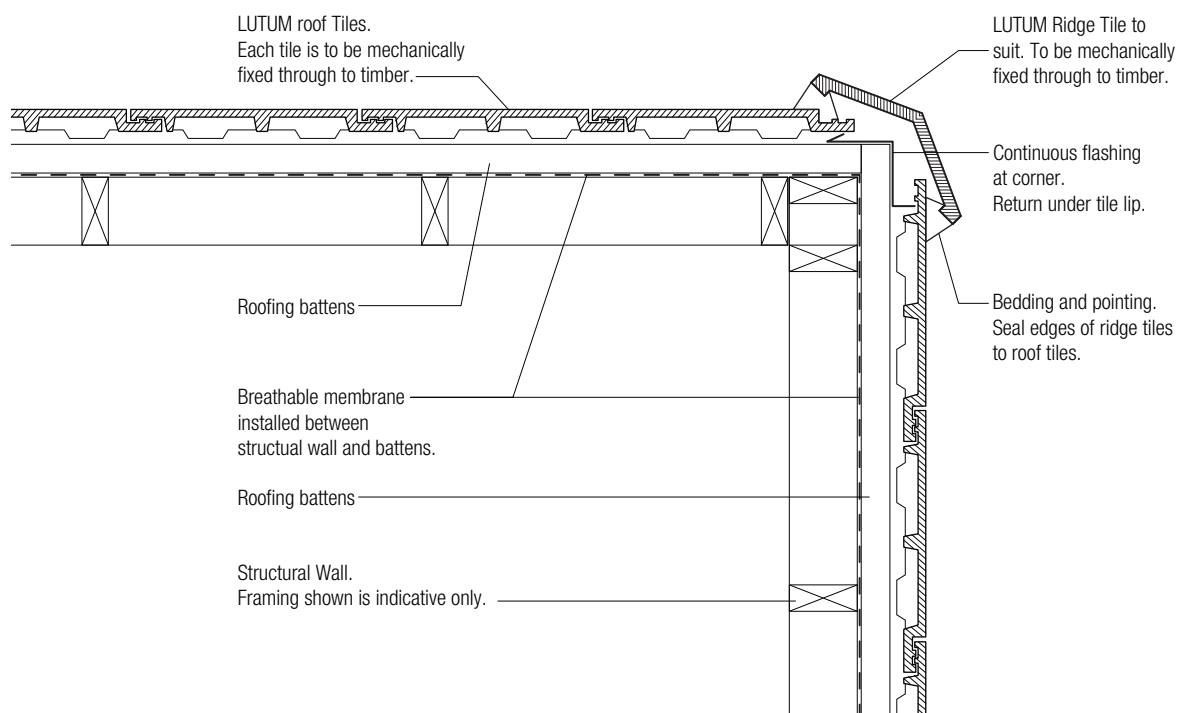

Figure 69: **Vertical Tiles at External Corner - Option 1** (CAD File BR020 - Available on request)

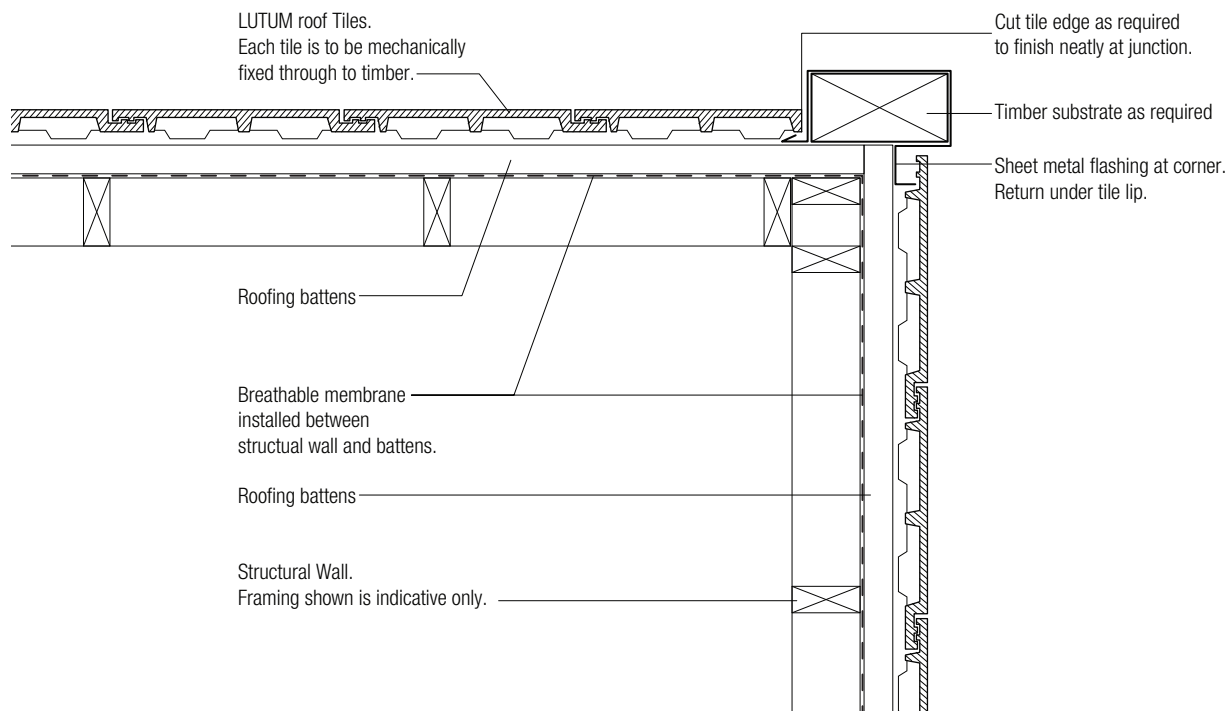

Figure 70: **Vertical Tiles at External Corner - Option 2** (CAD File BR021 - Available on request)

» Architectural Details

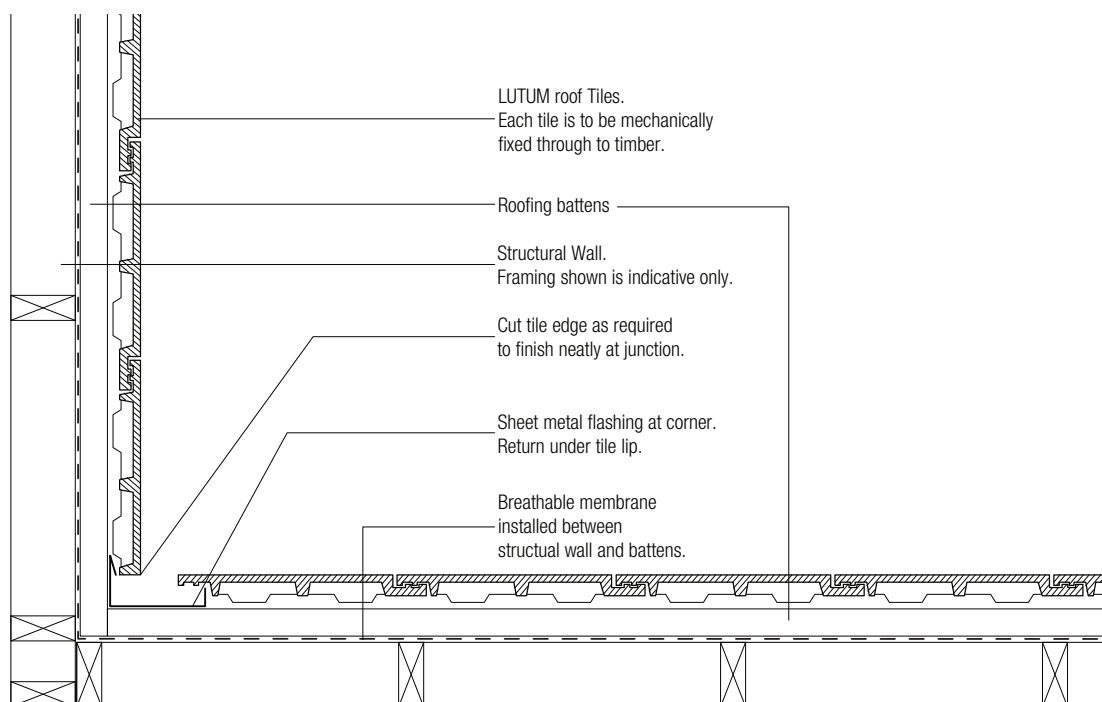

Figure 71: **Vertical Tiles at Corner - Option 1** (CAD File BR022 - Available on request)

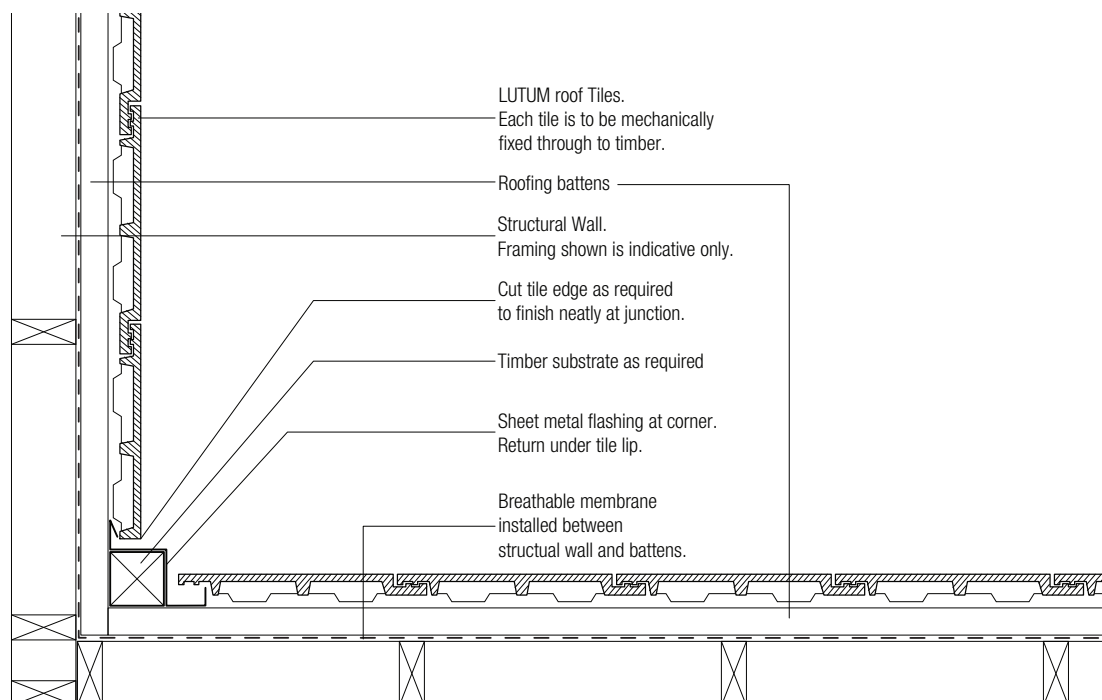

Figure 72: **Vertical Tiles at Corner - Option 2** (CAD File BR023 - Available on request)

» Architectural Details

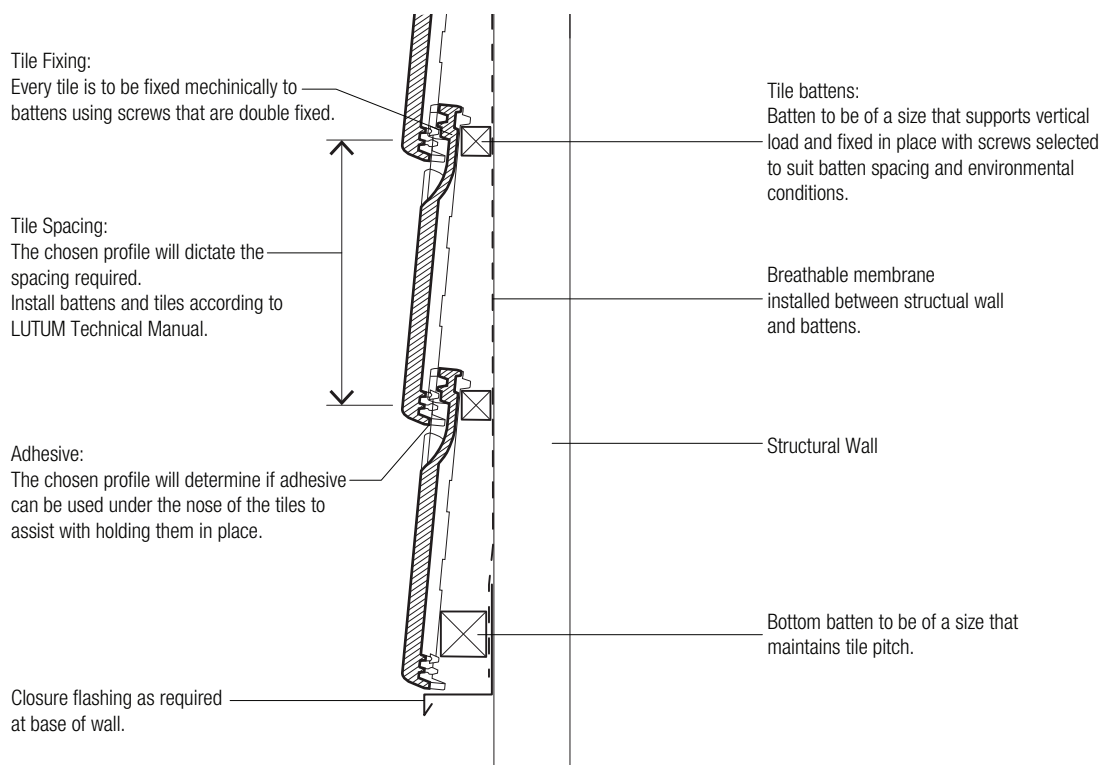

Figure 73: **Vertical Tiles - Wall - Option 1** (CAD File BR024 - Available on request)

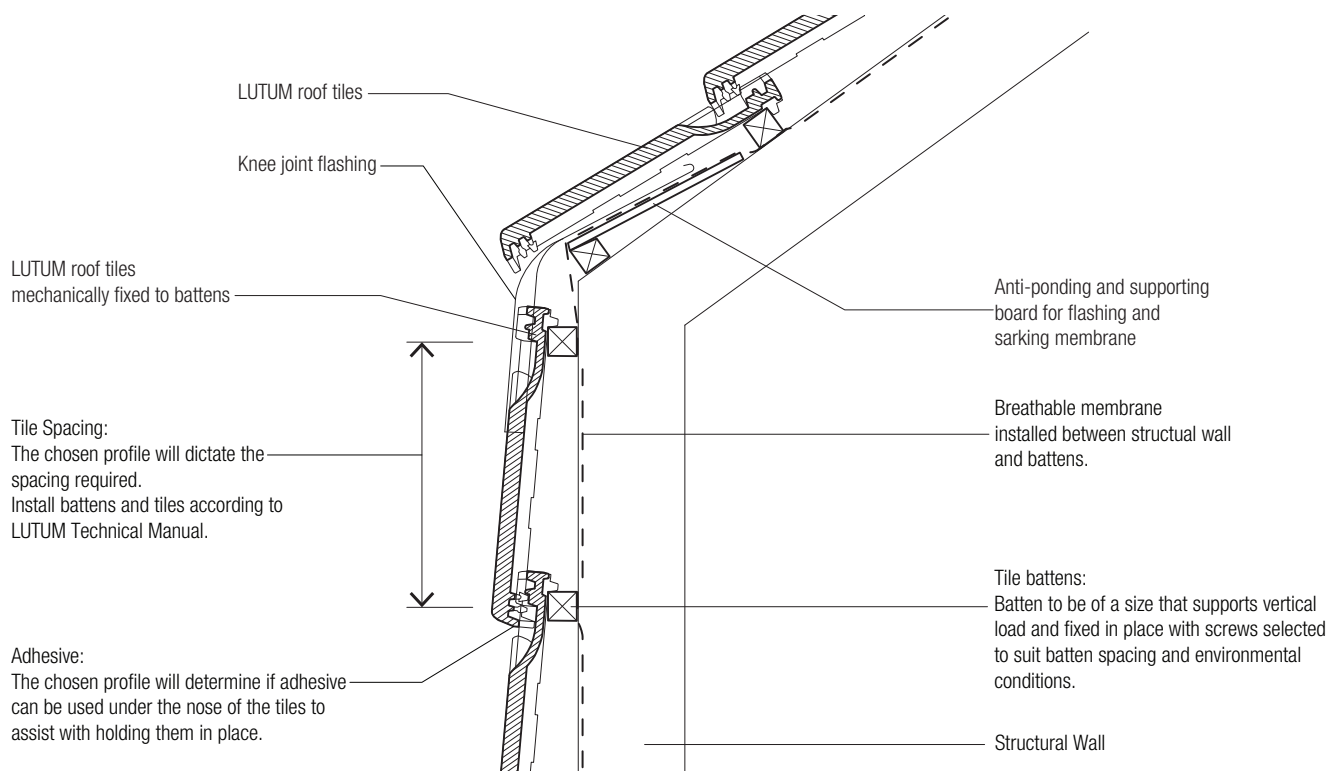
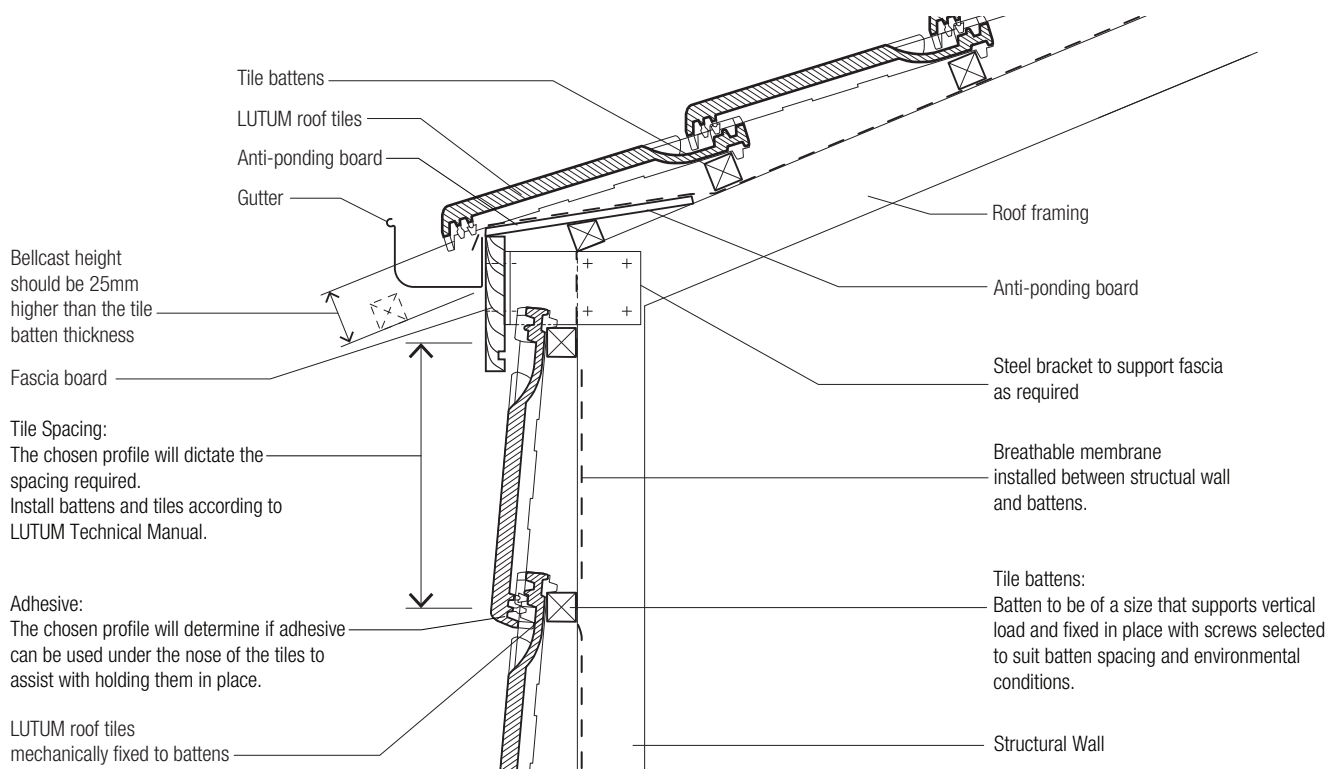
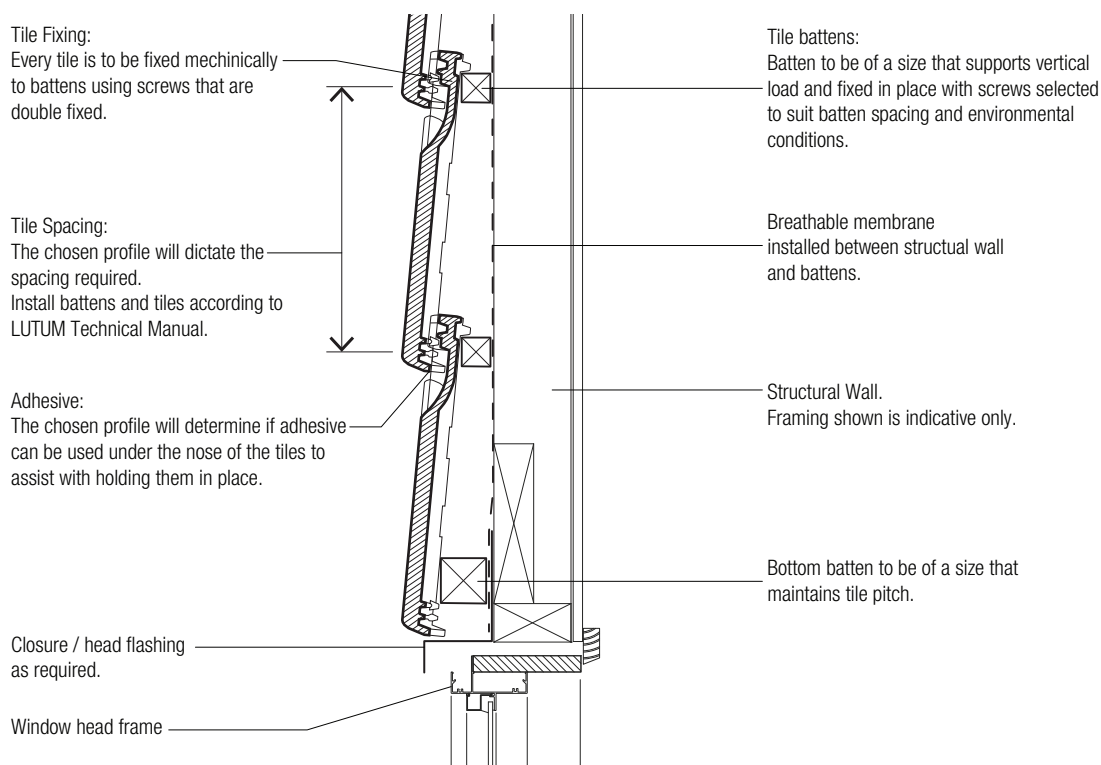
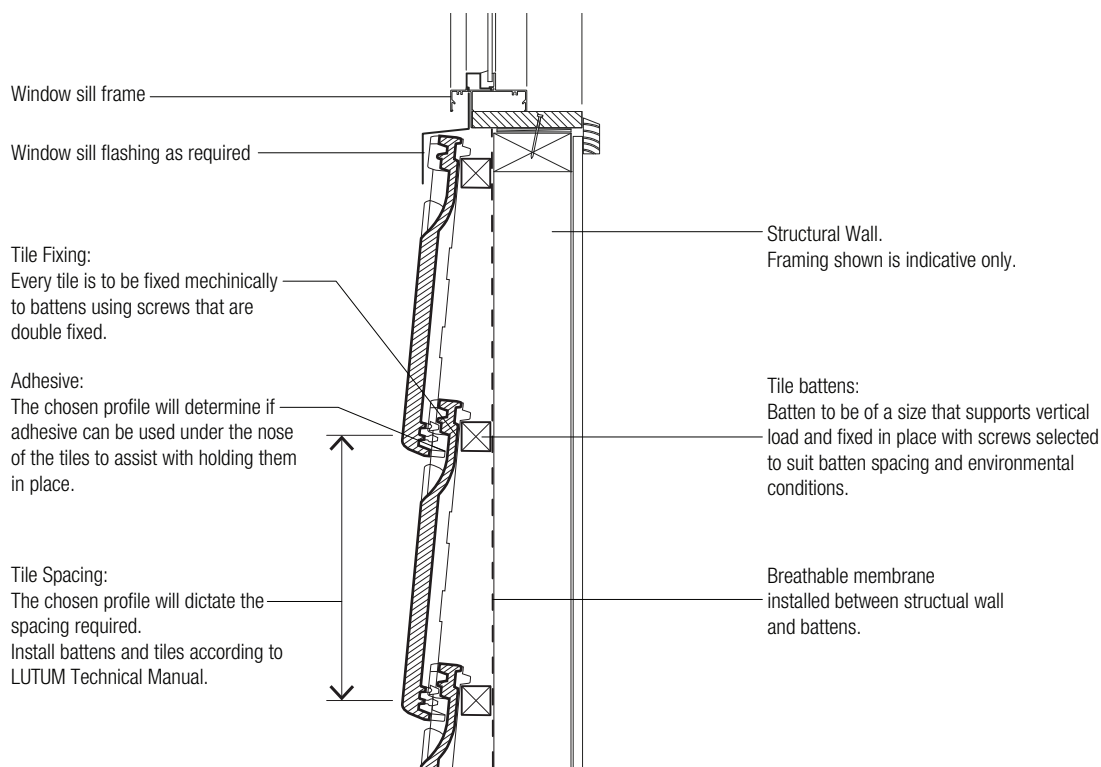

Figure 74: **Vertical Tiles - Wall - Option 2** (CAD File BR025 - Available on request)

» Architectural Details

Figure 75: **Vertical Tiles - Roof Junction Detail** (CAD File BR026 - Available on request)

» Architectural Details

Figure 76: **Vertical Tiles - Window Head Detail** (CAD File BR027 - Available on request)Figure 77: **Vertical Tiles - Window Sill Detail** (CAD File BR028 - Available on request)

LUTUM Roof Tiles Technical Information Guide

Frequently Asked Questions



Frequently Asked Questions

How do I best maintain my roof?

Maintaining tiles requires minimal effort however should be done regularly. This includes cleaning gutters, downpipes and valleys as well as the roof itself. If your roof is old or you'd like to get it checked after storm damage, we recommend contacting a roof maintenance specialist who understands the correct safety procedures to inspect and clean your roof.

Can I respray tiled roofs?

Depending on the material and method used it is completely acceptable to spray concrete roof tiles. However, never spray terracotta as it would interfere with the natural quality of the clay and over time will peel away from the glazed surface. Water collected during respraying, should not be collected in water tanks.

Why is concrete not as colour-fast as terracotta or ceramic?

Concrete tiles are not glazed so like all exterior building materials they are subject to UV radiation and atmospheric pollutants. As a result they will weather with age to a matt finish and will lose some colour over time. Terracotta tiles are kiln-fired with vitreous coating that makes these tiles resistant to harsh UV exposure.

What is lichen?

Lichen or moss can start to grow on tiles after long periods but does not in any way indicate deterioration or affect the performance of tiles. It can be easily removed with a high pressure cleaner by a professional cleaning contractor.

What are the white streaks apparent on some roofs?

Sometimes the natural mineral salts in concrete can migrate to the surface in the form of whitish grey discolouration called efflorescence. This is not harmful, has no impact on the performance of the tile and will weather away over time.

How expensive is it to re-roof?

Bring your plans into a LUTUM display or contact us on 1300 134 002 and we can help you with a cost estimate. There may be surprisingly little difference between the cost of respraying and installing new roof tiles.

How long will it take to install my roof?

The average roof is around 210 square meters, which takes approximately two days to install and fix. Allow another day for each additional 100 square metres.

I live near the water, is my warranty still valid?

The LUTUM roof tile guarantee is valid no matter where you build your home and not dependent on how close or far you are from the coast. All LUTUM roof tiles are salt safe and can be used even in severe marine environments.

What is NatHERS or BERS?

The Nationwide Housing Energy Scheme (NatHERS) and Building Energy Scheme (BERS) are energy simulation computer programs that provide thermal ratings for homes. They are employed during the design stage to enhance the energy efficiency of a new development.

Notes

Notes



Enquiries

1300 134 002

Web

www.lutum.com.au

Important Information: Product information contained in this brochure is correct as at July 2022 and is subject to change thereafter without notice. The photos and images contained in this brochure are for illustrative purposes only and should not be used or relied upon for final selection. LUTUM roof tiles are manufactured from natural products which feature variations in colour, texture, shape and may also include minor blemishes and chips from manufacture and delivery which are not defects and do not affect the performance of the product. For this reason it is important that you view a display and physical samples before ordering, and ensure that roof tiles from any order are blended from a number of pallets across a roof to achieve consistency. At LUTUM, all roof tiles are manufactured to the requirements of Australian Standard 2049-2002 Roof tiles. Please ask for and review a copy of the conditions applicable to the LUTUM Warranty before making your purchase. LUTUM, the LUTUM logo, Shingle, Artline, Wave, French, Swiss, Contour, Slimline, Macquarie, Capri, Vogue, Linea, Striata are trade marks or registered trade marks of LUTUM Holdings Pty Ltd. or one of its subsidiaries. Montoro Roofing Pty Ltd ABN 34 002 944 694 trading as LUTUM.